

EXPERIMENTAL AEROGENERATOR  
TYPE B.E.S.T. — ROMANI  
DESCRIPTION, ASSEMBLY, TEST PROGRAM

(NASA-TT-F-15037) EXPERIMENTAL  
AEROGENERATOR TYPE BEST - ROMANI,  
DESCRIPTION, ASSEMBLY, TEST PROGRAM

N73-29004

(Scientific Translation Service) 5750 p HC

CSCL 10A G3/03 Unclas 11441

Translation of: "Aérogénérateur Expérimental  
Type B.E.S.T. - Romani Description - Montage  
Programme d'essai," Service Des Etudes Et  
Recherches Hydrauliques, Division Energie  
Du Vent, 20, Rue Hamelin, Paris, Electricité  
De France, May 1958, pages 54.

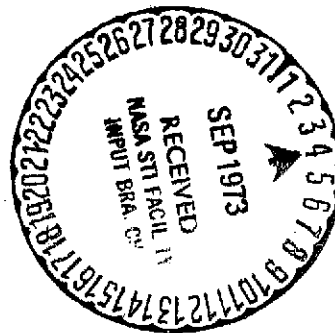

NATIONAL AERONAUTICS AND SPACE ADMINISTRATION  
WASHINGTON, D.C. 20546 AUGUST 1973

Reproduced by  
NATIONAL TECHNICAL  
INFORMATION SERVICE  
US Department of Commerce  
Springfield, VA. 22151

**N O T I C E**

**THIS DOCUMENT HAS BEEN REPRODUCED FROM  
THE BEST COPY FURNISHED US BY THE SPONSORING  
AGENCY. ALTHOUGH IT IS RECOGNIZED THAT CER-  
TAIN PORTIONS ARE ILLEGIBLE, IT IS BEING RE-  
LEASED IN THE INTEREST OF MAKING AVAILABLE  
AS MUCH INFORMATION AS POSSIBLE.**

1. Report No. NASA TT F-15,037	2. Government Accession No.	3. Recipient's Catalog No.	
4. Title and Subtitle EXPERIMENTAL AEROGENERATOR TYPE B.E.S.T. ROMANI DISCRPTION, ASSEMBLY, TEST PROGRAM		5. Report Date August 1973	
		6. Performing Organization Code	
7. Author(s)		8. Performing Organization Report No.	
		10. Work Unit No.	
9. Performing Organization Name and Address SCITRAN Box 5456 Santa Barbara, CA 93108		11. Contract or Grant No. NASw-2483	
		13. Type of Report and Period Covered Translation	
12. Sponsoring Agency Name and Address National Aeronautics and Space Administration Washington, D.C. 20546		14. Sponsoring Agency Code	
		15. Supplementary Notes Translation of: Aérogénérateur Expérimental Type B.E.S.T. - Romani Description - Montage Programme d'essai Source: Service Des Etudes Et Recherches Hydrauliques, Division Energie Du Vent, 20, Rue Hamelin, Paris, Electricité De France, May 1958, pages 54.	
16. Abstract  A propeller-driven electrical wind generating machine with a 30 meter diameter propeller is described. The 160 ton machine, with a power rating of 640 kW, was built at Nogent-Le-Roi, France in 1958.			
17. Key Words (Selected by Author(s))		18. Distribution Statement  Unclassified - Unlimited	
19. Security Classif. (of this report) Unclassified	20. Security Classif. (of this page) Unclassified	21. No. of Pages 49	22. Price

## TABLE OF CONTENTS

I	Location and installation	(Fig. 1)
II	Description of the study station and the aerogenerator	(Fig. 2)
	A) Infrastructure	
	B) Tilttable part	
	a) Pylon tripod	(Fig. 3)
	b) Moveable pivot with fairing	(Fig. 4)
	c) Nacelle	(Fig. 5)
	d) Generator	
	e) Eolian propellor	(Fig. 6)
	f) Transmission	(Fig. 7)
	g) Rate and power limiters	(Fig. 8)
	h) Orientation	
	i) Weight breakdown	
	C) Electrical installation	(Fig. 9)
III	Installation	
IV	Preparation for operation	
V	Measurements	
	A) Purpose of the test - Measurement quantities	
	B) Material to be used	
	C) Test duration	
VI	Selected photographs	
VII	Remarks	

EXPERIMENTAL AEROGENERATOR  
TYPE B.E.S.T. — ROMANI

DESCRIPTION, ASSEMBLY, TEST PROGRAM \*

I. LOCATION AND INSTALLATION.

The wind energy study station includes an aeolian propellor / 2\*\* aerogenerator having three blades and a diameter of 30.19 meters. The test facility includes about 2 1/2 hectares. It is located 2 km Southwest of Nogent-Le-Roi (Eure et Loir). It is situated on Highway No. 148 from Courville (Figure 1).

Even though the area does not have particularly strong or frequent winds, it was selected because the winds are very regular on a scale of one minute. Also there is a large plateau which surrounds the station. There is an extensive plateau region in the primary wind direction as well.

In this way, there are no houses, trees or substantial undulations. The station is not located close to the ocean. Such conditions would lead to regular performances of the device when meteorological conditions change.

The site is not located in the area around Paris. Thus the experimenters will not be subjected to various pressures.

---

\* French Electrical Corporation Research and Study Directorate Hydraulic Research and Study Service. Wind Energy Division, 20 Rue Hamelin, Paris 16, May 1958.

\*\* Numbers in the margin indicate pagination of original foreign text.

Light pylons have been erected around the apparatus, one of which is 60 meters long. They are made as transparent as possible to the wind. They support the control instruments for directional control and must withstand the wind velocity.

## II. DESCRIPTION OF THE STUDY STATION AND THE AEROGENERATOR.

The device is shown in Figure 3. It was constructed under the direction of the research and study department of the French Electrical Corporation. Plans were used which were prepared by the technicians from the Scientific and Technical Study Bureau, 12 Rue Léonidas, Paris 14<sup>e</sup>. This agency is directed by Mr. B. Romani, engineering consultant.

### A. Infrastructure.

The infrastructure consists of a platform with assembly terrace, a few meters above the ground. It is star-shaped and two branches are of a light construction so that they can be easily moved (extendable tubes). The third member consists of a small building which houses the transformation station, the command room and measurement room, the building containing the batteries, the room for measuring the load and the excitation of the alternator as well as a small office. A hanger which serves as a storage area is also included. The foundations of the aerogenerator include three concrete substructures located at the corners of an equilateral triangle of approximately 26 meters side length. (Each of them rests on solid earth plane limonin to a depth of approximately 1 meter).

The symmetric substructures B and C have a volume of about 70 m<sup>3</sup> each. At zero level they support the two feet of the pylon about which the tilting operation takes place. The substructure A has a volume of about 60 m<sup>3</sup> and supports the foot

which is displaced during the balancing operation, and uses a mechanical screw device.

13

Two additional concrete substructures (called North and South substructure) have a volume of about 50 m<sup>3</sup> and support members in which the winches of the asynchronous motors are located. These drive the traction cables and the holding cables for the aerogenerator during the tilting operation.) (The operational command is done by means of an intercom system from a building located to the East in the vertical plane passing through the hinges B and C). The North substructure is also used to support the portico on which the tilted aerogenerator rests.

The connection with the main net is made through a 15 kilovolt line 12 kilometers long, approximately. Figure 1 shows the path of this line. Also there is a transformer with ample capacity (3 MVA) which is located at Maintenon (Eure et Loir). It makes a connection between this 15 kV line and the 63 kV Elancourt-Buisant line.

#### B. Tilttable part

##### a) Pylon tripod

The pylon is shown in Figure 3 and was built at Montreau (Seine et Marne) by the company (\*).

The primary pylon structure consists of a triangle system in space, made up of four juxtaposed tetrahedra (15 bars, 17 nodes). One of the horizontal surfaces of the central tetrahedron makes up the upper pylon platform at a level of 15 meters.

---

\* Translator's note: Words illegible in foreign text.

The corner opposite this side is the 8.5 meter level. The socket node center of this member supports the pivot. The other 3 tetrahedra are identical and each have a common side with the three lateral sides of the preceding tetrahedron. The facing corners of these sides are at zero level. The level points of the nodes make up the foot of the pylon.

For various reasons, especially in order to save time, the required steel was taken from the inventory of the construction firm. The pylon tripod weighs 102 tons (tiltable part only).

b) Moveable pivot with fairing.

The pivot shown in Figure 1 is a tube made up of two opposed cones with a total length of 22 meters. It is made of steel sheet metal and welded to a depth of 18 mm.

The central part of it consists of a cylindrical rolling surface part made up of heavy steel. The rollers, mounted in pairs along six rudder bars, press against the rolling surface. The vertical axes of the rudder bars are connected with the pylon.

An external fairing made up of thin steel sheet metal contains the access ladder to the nacelle. It is there in order to reduce the interaction between the wake and the eolian propellor located downstream.

c) Nacelle

The nacelle, Figure 5, made of thin riveted steel sheet metal is installed within the interior of the upper extremity of the pivot. It supports the upstream fairing and the brake fairing.



The nacelle is extended in the upstream direction by the brake and by means of a forged steel member. This is done by means of a large dimension ball bearing which supports the eolian propellor. It is surrounded by two foot bridges located above one another. One of them contains the hydraulic control devices.

d) Generator

The (\*) generator, 3,000 Volts, 1000 rpm, 640 kW, 800 kV, is installed in the frames of the nacelle. This generator has separate excitation (on the ground) and is supplied by a powerful squirrel cage damper. It is used to start the asynchronous motor.

The flexible ground connection cables (3-phase excitation, measurement cables and probe cables) are run vertically within the interior of the pivot and can sustain a torsion of somewhat more than one rotation.

e) Eolian propellor

Each of the three blades (Figure 6) is made of unoxidizable light alloy (AZ 4 called T 33, made by (\*) at Le]Havre) and is made with a riveted construction. The roots of the blades are made of riveted steel and are bolted. There are two flanges of steel. These parts make up the hub. The dihedral is 8°.

The hub is extended by means of an upstream cylinder connected with the brake. Also there is an upstream cone which engages the

---

\* Translator's note: Illegible in foreign text.

coupling. These auxiliary structures are made of steel. The hub has a fairing between the blades. Also there are removable fairings made of T 35. There is a turning device for manual turning of this propellor. Under normal conditions, it turns at 17 rpm. It was constructed at Bordeaux (Gironde) and part of it was constructed at Valencionnes (Nord). The fabrication was performed at the Industrial Transport Material Company.

#### f) Transmission

A device used on electrical locomotives has been extended. The eolian propellor drives a first planetary gear train, having the following characteristics: interior tooth fixed crown (Model 11) with 109 teeth, three 46-tooth satellites and a 17-tooth planetary gear.

An intermediate shaft having an exterior diameter of 260 mm revolves at 350 rpm and connects the first gear to the second gear train. It passes through the center of the journal supporting the propellor. Couplings with "boat" notches allow a certain misalignment. These misalignments are unavoidable because of the large size of the structure.

The following characteristics apply to the second gear train: crown driven by an intermediate shaft (module 8, 77 teeth); one 25-tooth satellite connected with the clutch by means of a shaft which drives the satellites. These pass through the crossed shaft of the generator. Twenty seven-tooth planetary gears.

The teeth of the two trains are right angle ones. The fixed part of the clutch is balanced and strain gauge rods make it possible to measure the reaction moment on the nacelle. 15

The transmission, the pivot and the nacelle were built by the Mediterranean Forgery and Steelworks (Le Havre Division - Maritime Seine Division.

Figure 7 shows a diagram of lubrication for the two gear trains.

g) Rate and power limiters

If the blades of an eolian propellor have a fixed adjustment, a very effective control is obtained automatically and without cost by connecting the generator with an alternating current network.

In effect, the incident wind is the geometric sum of a relative component due to rotation and the natural wind. When the rate of rotation is constant, the wind increases and the velocity triangle is deformed. Due to the effect similar to the "velocity loss" over an aircraft wing, the power produced by the propellor through the generator can decrease after passing through a maximum. It begins to increase again slowly only for considerable wind velocities.

On the other hand, the propellor will race when the network fails. The BEST-Romani aerogenerator has four methods of counteracting this situation.

The most classical solution is a disc brake with hydraulic controls, with which it is possible to apply a resisting moment of 40,000 m kG to the propellor. The components selected have an increased effectiveness as temperature increases, in contrast to what is used in automobiles. An electrical brake can be obtained by substituting an electrical resistance for the failed

network. This distance consists of a 160 meter long, three phase suspended line which is cooled by the wind and made of three lengths of flat TOPHET ribbon arranged in the shape of a star. This resistance can dissipate up to 1100 kW.

Slowing down devices, called "spoilers", are installed on each blade. Under normal operating conditions, they are retracted into the leading edge. When they are extended, under the influence of centrifugal force, they can instantaneously destroy the aerodynamic properties of the profiles used.

Finally, if none of these procedures can slow down the propellor, it may be possible to change the orientation of the entire aerogenerator installation.

Figure 8 shows the hydraulic command units.

#### h) Orientation

Above the upper pylon platform, there will be an electrical command gear mechanism with which it is possible to change the orientation of the pivot. This command itself can be servo-16 controlled by means of an air sleeve outside of the wake of the eolian propellor.

#### i) Weight breakdown of the tiltable part

Pylon . . . . .	102 tons
Pivot with fairing. . . . .	25 tons
Nacelle . . . . .	10 tons
Generator . . . . .	6 tons
Eolian propellor and rotating fairings . . . . .	8 tons
Transmission . . . . .	<u>9 tons</u>
Total. . . . .	160 tons

### C. Electrical installation

It is shown in Figure 9. The selector makes it possible to operate in the safety mode using the local 15 kilovolt system. It is usually open.

Very detailed instructions for operating the installation at Nogent-Le-Roi were worked out with various interested services of the French Electrical Corporation. This was done so as to avoid any accidents involved with supplying the energy generated by the wind to the 63 kilovolt general network.

### III.] INSTALLATION

The installation work for the aerogenerator was started in 1955. The buildings and these foundation substructures were built in 1956 as well as part of the electrical installation. These were built by the Anthony (Seine) French Electrical Society.

The installation of the tiltable part could only be started in the year 1957. This was because of labor problems of the installation and worker's union of Villejuif (Seine).

Some work remains to be done (balancing of the propellor, installation of the upstream and downstream fairings, installation of the orientation mechanism, mounting of spoilers, painting of the entire device) which will make it necessary to lower the tiltable part in the foreseeable future.

We believe that the entire installation will take up 18 months. During this period, the device will have operated and most of the running-in work and the preparation work will have

been completed.

#### IV.] PREPARATION FOR OPERATION

At Nogent-Le-Roi, the alternator was first connected with the net on March 15, 1958. It operated as a synchronous compensator.

The uncoupled propellor was set free in the wind on March 19, 1958. It was operated by a wind having a velocity of about 1.30 m/sec. When it reached the velocity of about 53 rpm, corresponding to a wind of 6 m/sec and a free-wheeling peripheral velocity coefficient ( $\frac{WR}{V}$ ) on the order of 14, it was stopped by the mechanical brake in about 7 seconds.

The alternator-propellor complex first delivered power to the net on April 2, 1958. On April 11, a power level on the order of 200 kW was reached for winds which varied between 7 to 11 m/sec approximately. The charge threshold seemed to be somewhat less than 7 meters/sec. For the time being and up until the running-in work has been completed, we do not want to exceed these values. 17

Between zero and 200 kW, there was no abnormal vibration or pumping to be observed.

#### V. MEASUREMENTS

##### A. Purpose of the test - Measurement quantities.

- a) Measurement of the performances of the device.  
Establish the following curves:

Useful power, wind velocity (free orientation,  
(slaved orientation,  
(displaced orientation, etc.)

- b) Analyze the electrical losses and derive the following curves:  
     Propeller power coefficient - wind velocity
- c) Determine the best excitation setting (Stability,  
     (Maximum production, etc.))
- d) Devise the following exploitation methods:  
     Permanent coupling or uncoupling because of wind velocity less than the charge threshold, requirement for a collector in the pivot, etc.
- e) Compare to various braking and slowing down procedures:  
     Mechanical braking, electrical braking, aerodynamic braking, change orientation by 90°.
- f) Study the possibilities of simplifying the maintenance:  
     Pivot fairing,  
     Orientation,  
     Slow motion, etc.
- g) Verify the calculations of the aerodynamics and the strength of materials. Provide information regarding the vibrations observed by measuring the stresses using wire strain gauges (in the eolian propellor, in the infrastructure, etc.) or by using differential micromanometers.
- h) Study the wakes.

B. Equipment to be used.

- a) Measurement of the direction and the velocity of the wind.
  - 1) Air sleeve containing selsyns and butterfly spinners
  - 2) Butterfly anemometer (sensitive to E) and anemometers which measure the theoretical collectible energy, built by the counter company at Montrouge (Seine).

- 3) Rough cylinder anemometers (with a response time on the order of 0.2 sec and which measure  $\bar{V}^2$ ).

- At the beginning, old model anemometers mounted as a wind vein.
- After that, astatic anemometers with two orthogonal components.

Note: The problem of a reference velocity is very difficult because of the following factors:

- 1) Interactions between the aerogenerator and the anemometers.
- 2) Because of the irregular nature of the wind in space.
- 3) Because of the non-steady character of the wind,
- 4) Because of the variable vertical gradient of its velocity.
- 5) Because of the orientation motions of the aerogenerator.
- 6) Because the cube of the velocity enters in the rate of reduction of the measurements.

If there is only one anemometer, it should be mounted on the same pivot as the aerogenerator, in order to function well. However, since this is impossible, it must be installed upstream by means of a horizontal mass in exactly the axis of the propeller. This means that it is not possible to carry out a calibration beforehand. This method can only be used if another device is available which is more accurate which is available for calibration in free air (an anemometer support has been planned upstream on the fairing in order to perform such a calibration). According to the recommendation of (\*) document 30.001 regarding low power aerogenerators for the A.F.N.O.R., it

---

\* Translator's note: Illegible in foreign text.



is possible to install two anemometers to the left and right of the eolian propellor at the level of the axis and at distances which are equal but not too large. At Nogent-Le-Roi, we use a 120 meter separation. This value is too large for the anemometers to be supported by the aerogenerator itself. This is why three pairs of support pylons were deemed necessary, (see Figure 1). At all times, only one pair was used.

b) Recording and reading of the instruments

1) A laboratory truck of the study and research directorate: recording of the transient operating ranges such as the starting of the alternator in the asynchronous mode during the connection process to the net and during coupling of the propellor.

2) With a simple photographic recorder, recording of the rotation rate of the propellor (free wheeling — deceleration at the time of braking, etc.)

3) Using a plate photograph device or an oscilloscope. Any variable can be used as the abscissa value (for example the power with modulation coupling (\*) and with any ordinate value: study of possible correlations. There is the possibility of recording the oscilloscope pictures on a movie camera.

4) By means of an ultra-fast camera: it is possible to take moving pictures of the propellor and to play them back slowly afterwards.

5) Using two accelerometers in conjunction located in a horizontal plane, located in the nacelle. Also a recorder

---

\* Translator's note: Illegible in foreign text.

is used. Detection and measurement of the overloads which probably exist when starting.

6) By means of a photographic, multitrack recorder: recording of watt meter readings, volt meter readings, angular separation between the wind and the propellor, readings of the coupling meter, readings of the rate of rotation, reading of the reference velocity and recording of the time.

Also, pivot gauges, reference velocity and time can be recorded as well as pylon gauges, reference velocity and time.

7) Using a recorder located inside the hub: recording the readings of gauges and transducers located in the blades, with remote controlled starting and synchronization with the recorder mentioned previously.

Note: A more ambitious program was planned which also included simultaneous measurements on the three blades using various numerous transducers and gauges connected to the multitrack recorder, which has radio transmission capability. In order to limit the expenses, this plan was abandoned. It will be possible to go back to this plan because of the fact that it is possible to balance the device. Also wires and pipes have been left inside inaccessible parts of the blades.

8) At Nogent-Le-Roi there are a certain number of instruments on the control panel at the control and measurement room. Their readings will simply be read off during a test. Only this will be done because the readings vary slowly (current intensity, probe temperatures in the (\*) of the stator of the generator, etc.); also the measurement variables could be mathematically related to quantities which are already recorded

---

\* Translator's note: Illegible in foreign text.

(varying mass of air, power factor). Also they are not recorded because some of them are only required over a certain time interval (oil flow rate). As far as the measurement of the air volume is concerned, there is a mercury barometer, as well as dry and wet thermometers.

9) We intend to study the wind at Nogent-le-Roi using, for example, electronic devices which will make it possible to make a classification according to frequencies. Also we will use devices made by the Transducer Society for recording the following curves: wind energy integrated over one minute, as a function of time. Also we can study the correlation between wind and rain (pluviograph recorder). Finally we may make use of the permanent personnel at the installation (during the day and during the night). We will use them especially if we are to take readings every hour over a period of several days.

#### C. Test duration

The tests have extended over several months. They are distributed over one year so that we will encounter the largest number of wind variations.

/10

#### VI. SELECTED PHOTOGRAPHS

This report also contains a number of photographs taken during the preliminary tests, the erection phase and the construction phase of the aerogenerator at Nogent-Le-Roi. We also show a photograph of the complete machine.

## VII. REMARKS

In order to test the idea of transforming wind energy into electrical energy we constructed a preliminary experimental device. The dimensions of this device may seem enormous considering the approximately one million and a half kilowatt hours which it is capable of producing per year, if it were located in Brittany or at Cotenin at a well selected site. We can see that the wind energy is not very dense.

The origins of this machine were inspired by machines used in industry or fabrication which are built in large series (automobiles, trains, electrical pylon supports, servo mechanisms). We were more concerned with techniques for providing safety rather than for reducing costs (aeronautics, marine technology, bridge construction). We were hampered by the fact that there was no precedent to our work. Our project will considerably simplify future work. It may become possible to omit elements which we had to include and which would have been impossible to add afterwards (clutch, multiplier, brakes, hydraulic controls, orientation, balancing, intermediate electrical transformation to low voltages, etc.).

The device at Nogent-Le-Roi is therefore a prototype. The large aerogenerators which may be built later on, on a small scale and provided the cost is not too large, may be quite different. However, their silhouette will be the same as will be their relative dimensions (\*).

---

\* Many words illegible in foreign text.

Figure 1.  
Study station for wind energy  
Nogent-Le-Roi  
(Eure et Loir)  
Location and installation

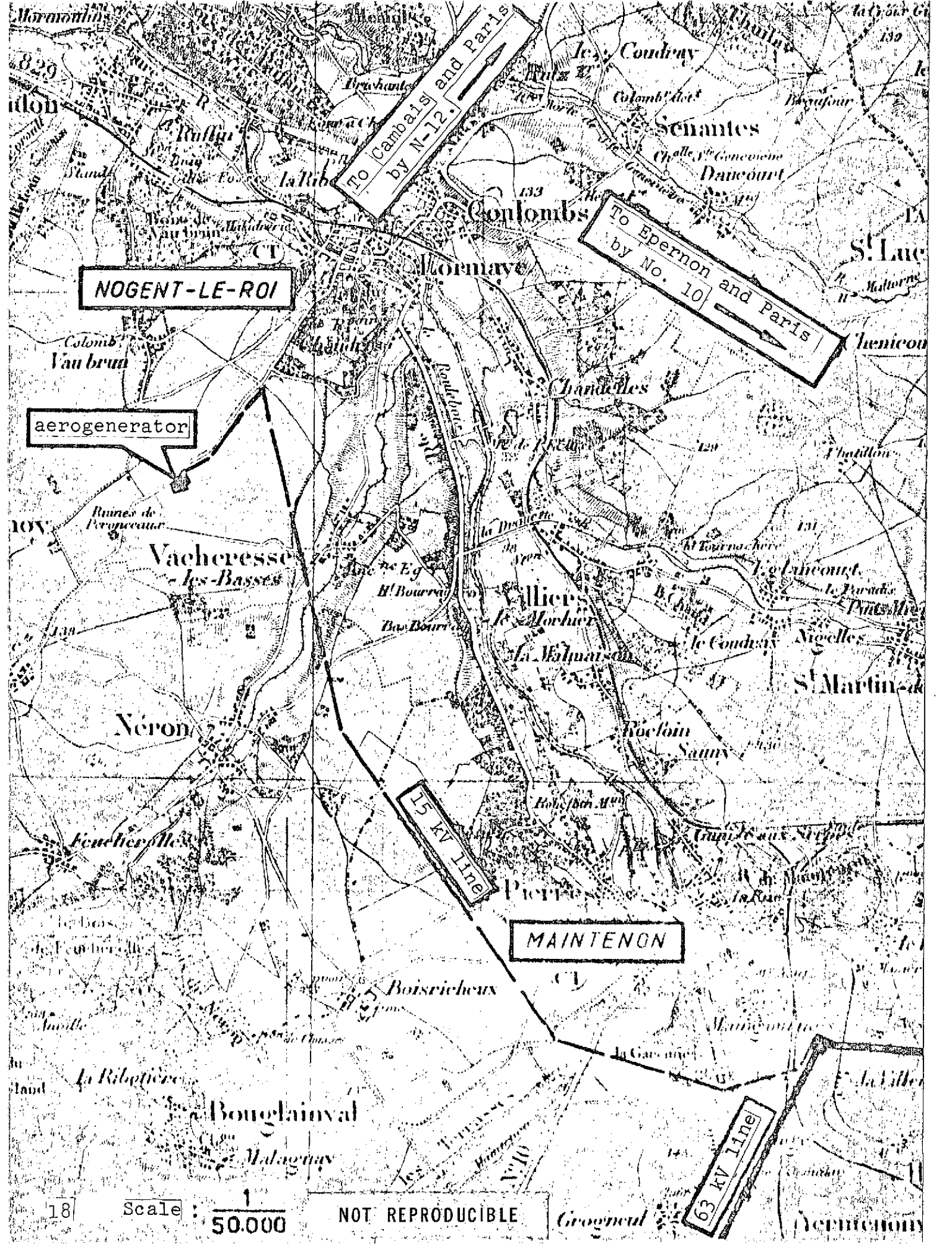

**NOGENT-LE-ROI**

**aerogenerator**

**TO Cambais and Paris  
by N-12**

**To Epernon and Paris  
by No. 10**

**15 KV Line**

**MAINTENON**

**63 KV Line**

- A-B-C: Substructure and feet of the pylon of the aerogenerator.
- D-E: Winches
- F: Aerogenerator
- G: Control and measurement building.
- H: Mounting platform
- I: Command unit for winches
- J: Resistance electrical line
- K: Hangar-storeroom
- L: Beginning point of 15,000 V suspended line
- (7: Supporting 60 m pylon which supports the directional air channel
- 1-2-3-4-5-6-8-9: 33 m pylon which support the anemometers

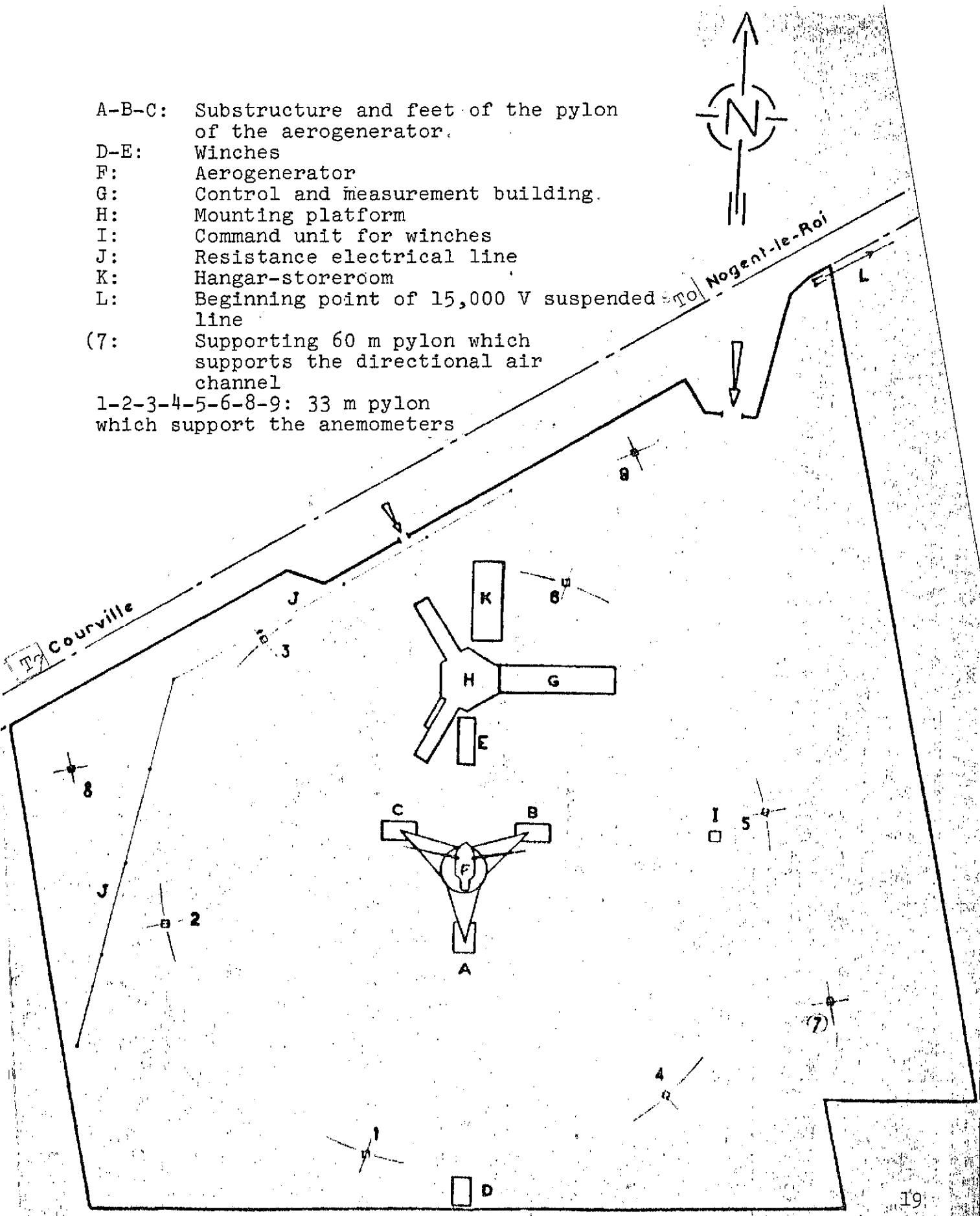

Scale:  $\frac{1}{1000}$

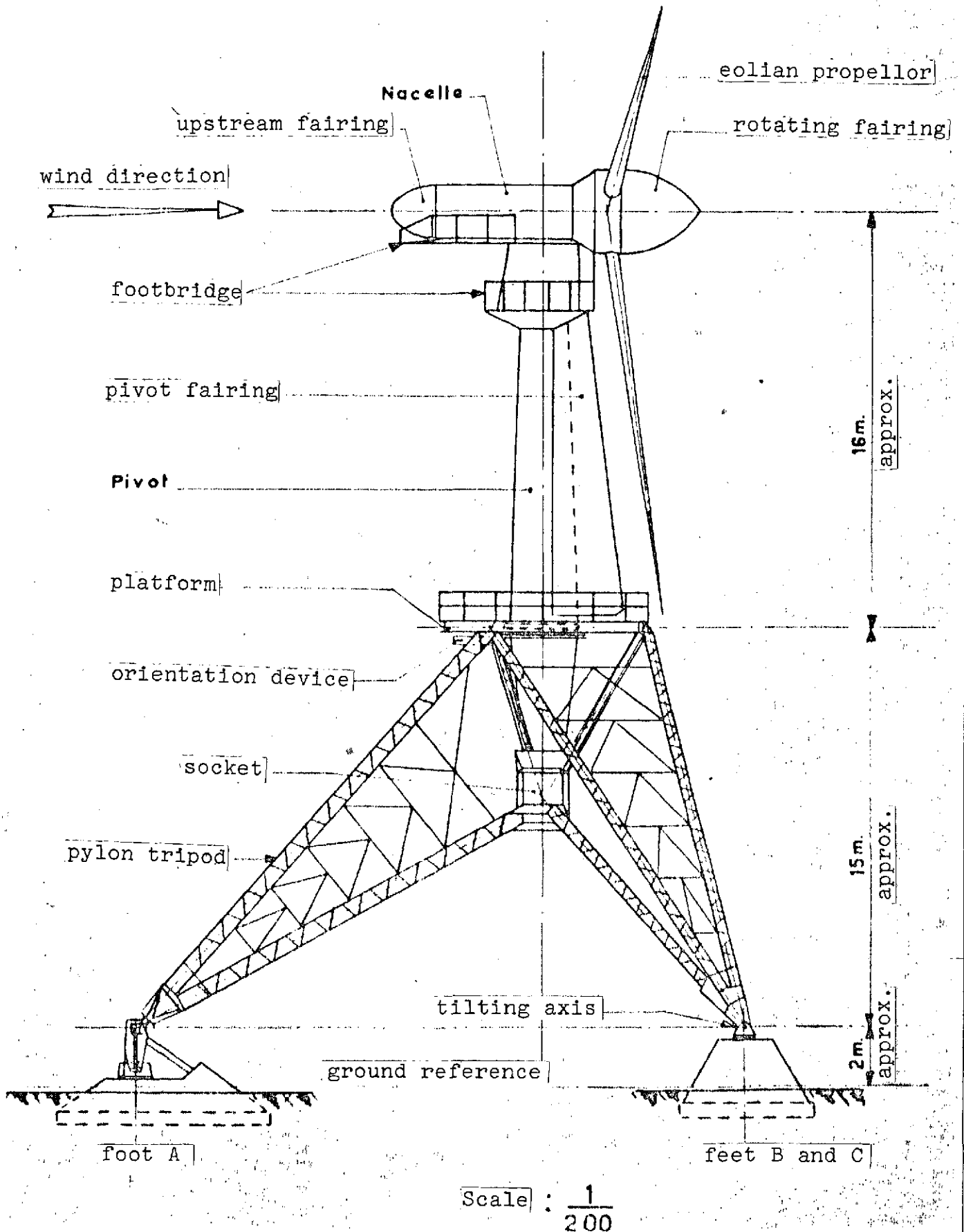

Figure 2. Entire aerogenerator complex.



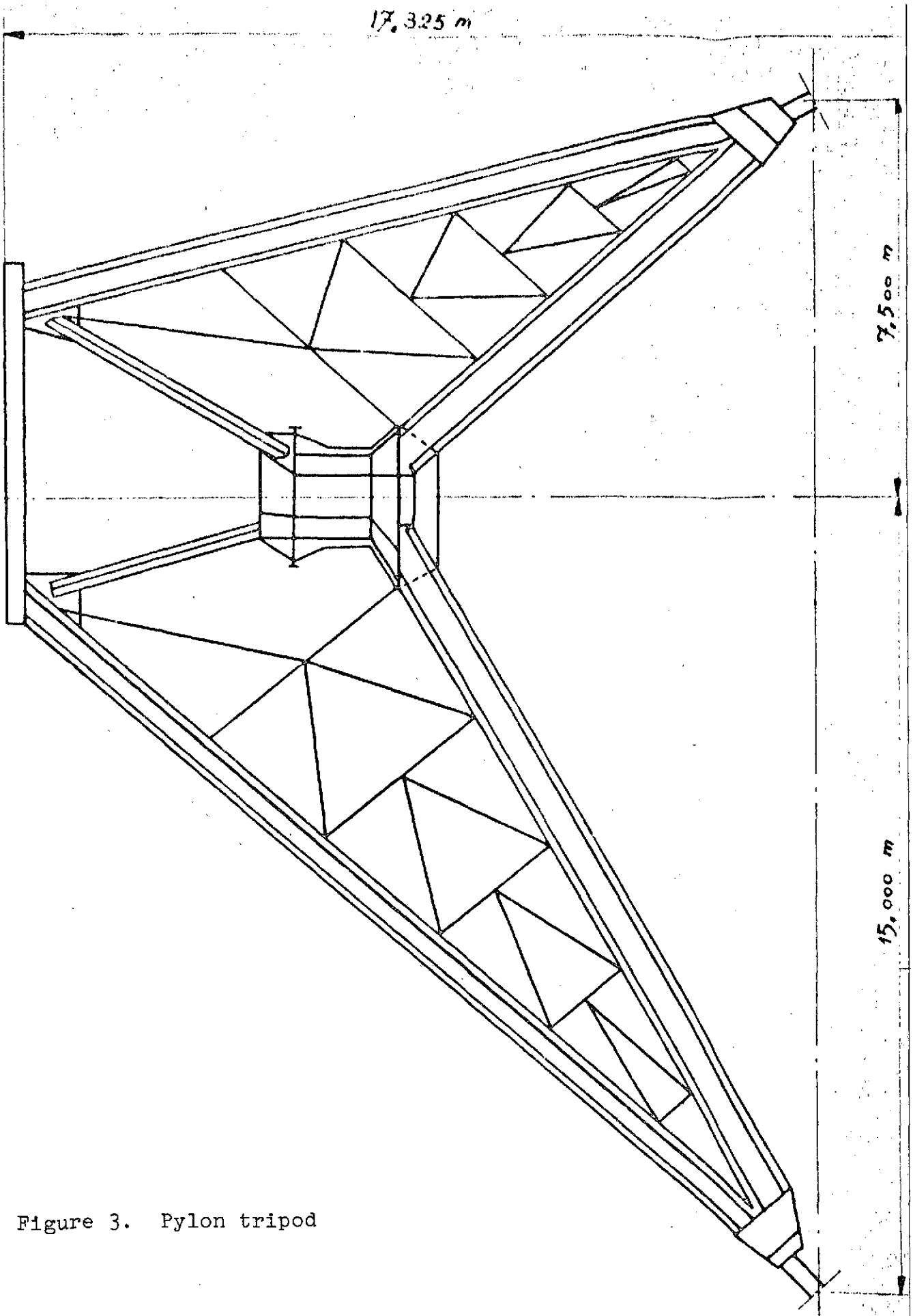
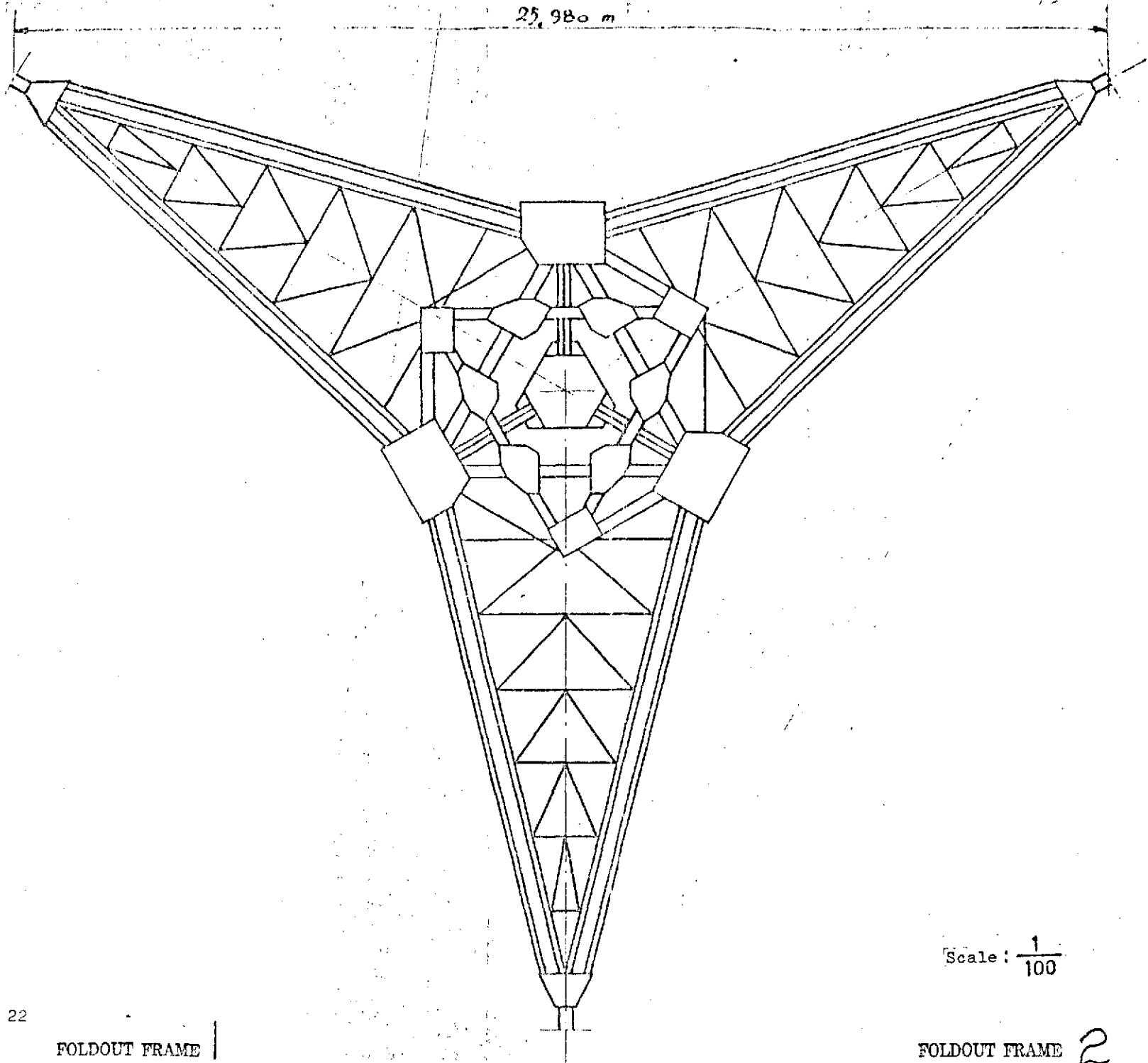

Figure 3. Pylon tripod

25,980 m



Scale:  $\frac{1}{100}$

Rotation shortage of the eolian propeller

1,350 m

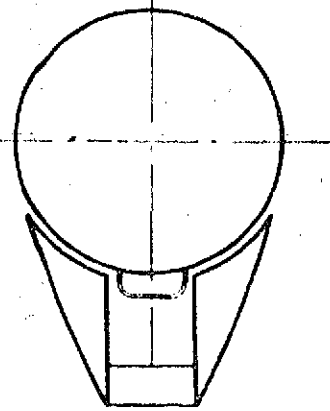
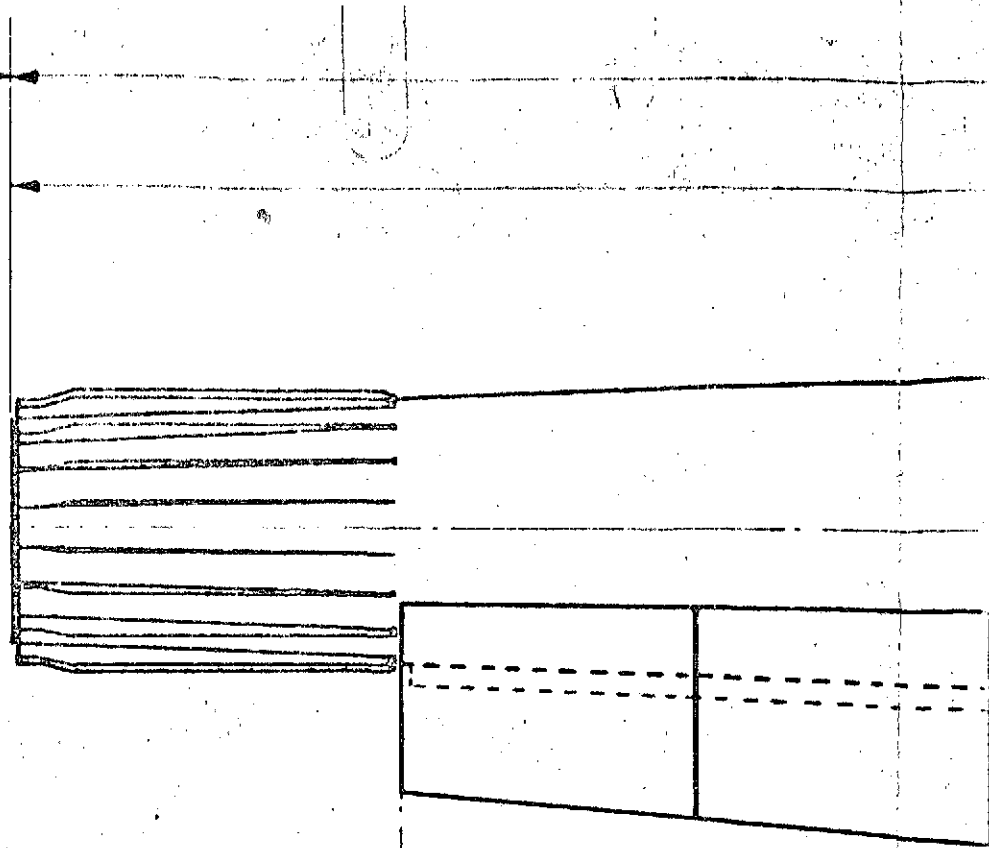

Figure 4. Pivot with fairing.

A

FOLDOUT FRAME 1

20,952 m

5 m

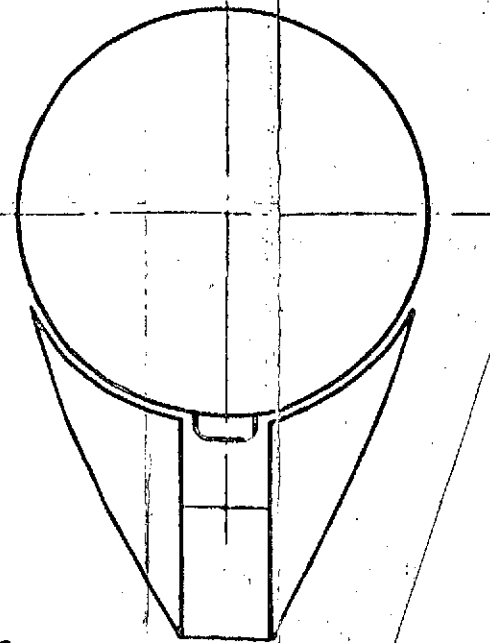
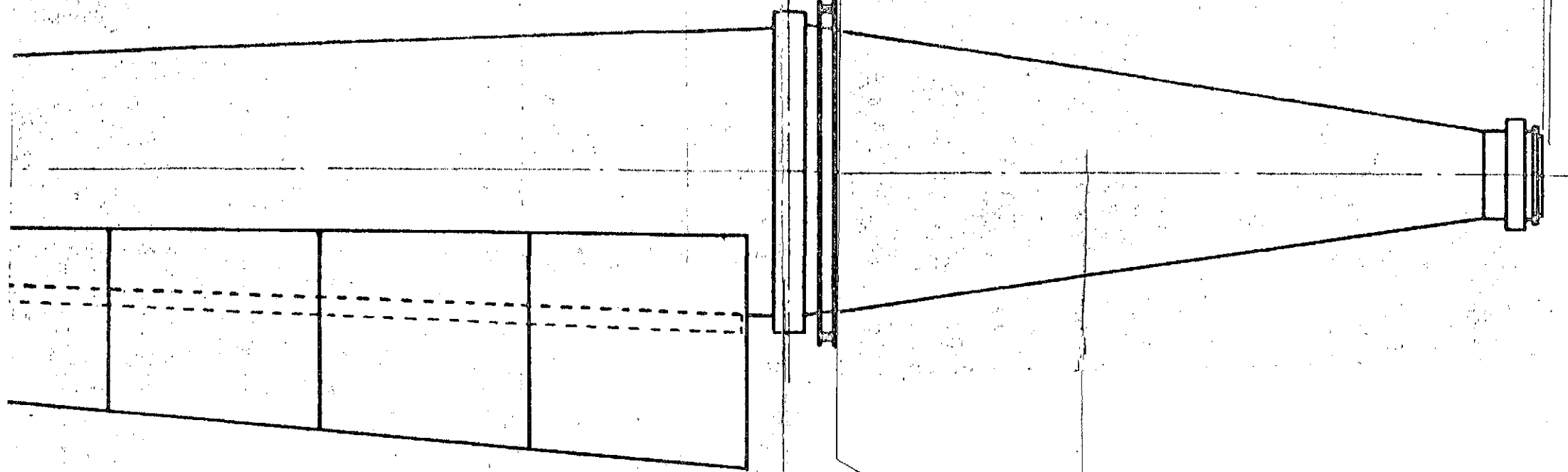

B

FOLDOUT FRAME 2

FOLDOUT FRAME 3

23

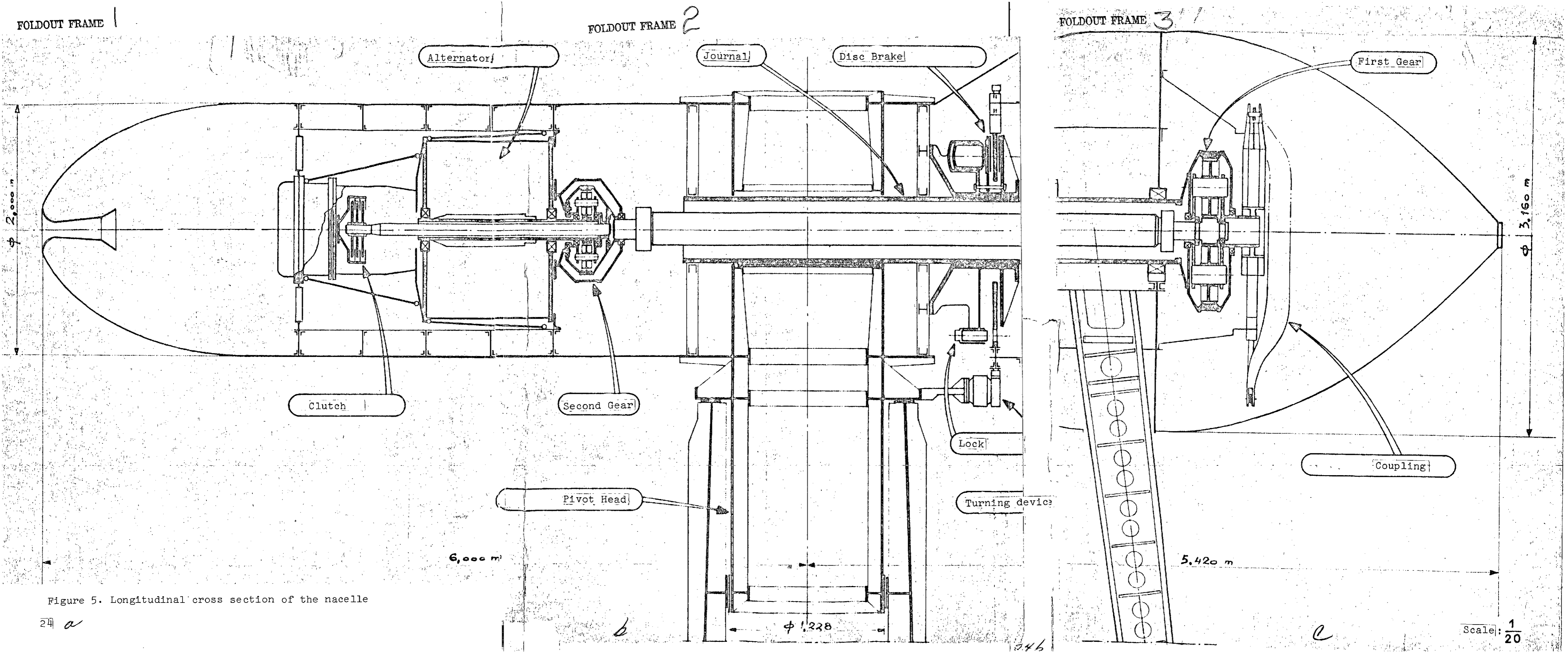
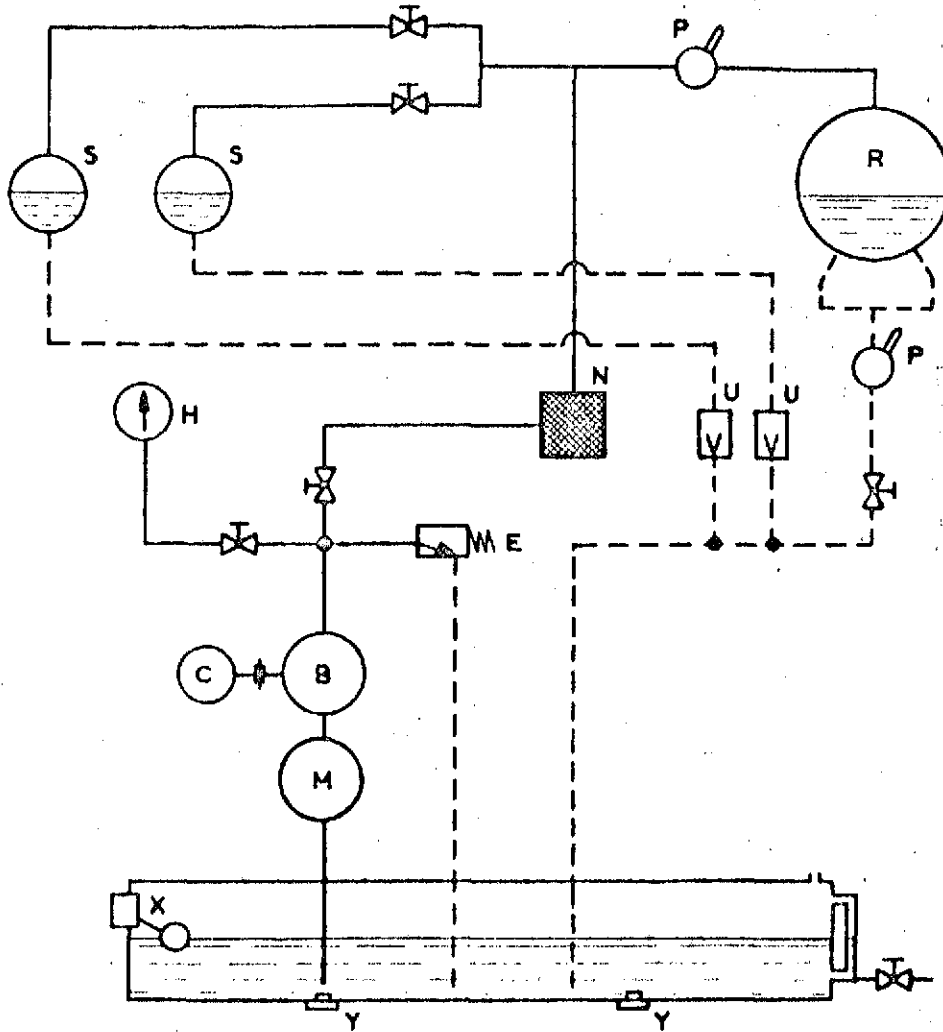

Figure 5. Longitudinal cross section of the nacelle

Page intentionally left blank

2nd gear and alternator bearings



- P: Thermal probe
- R: -1st and 2nd gear case
- S: Alternator bearings
- T: Overfill control
- U: Control flow rate
- V: Dispatch
- X: Level contact
- Y: Magnetic stopper

Figure 7. Lubrication circuits

Blade locking device

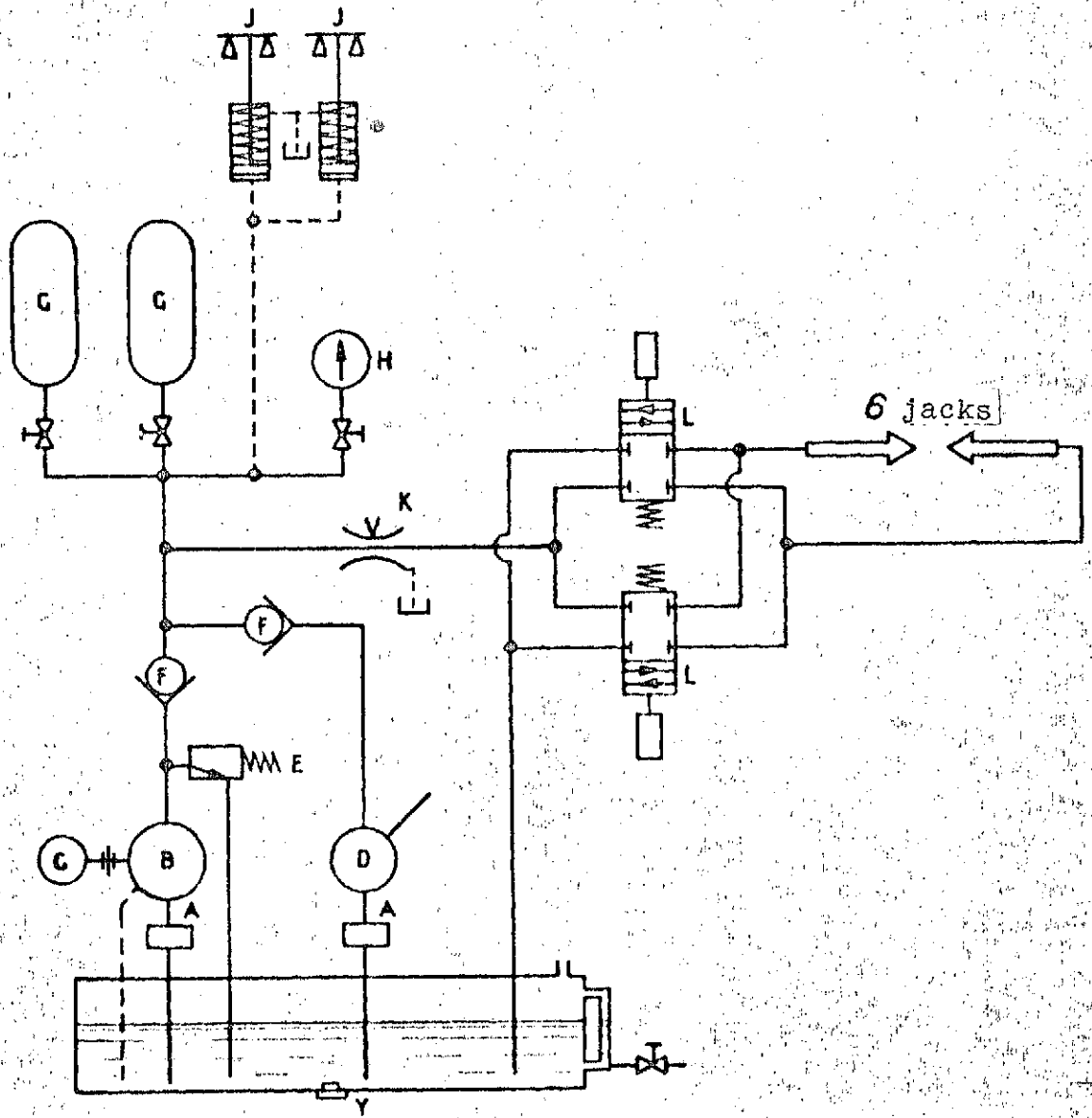
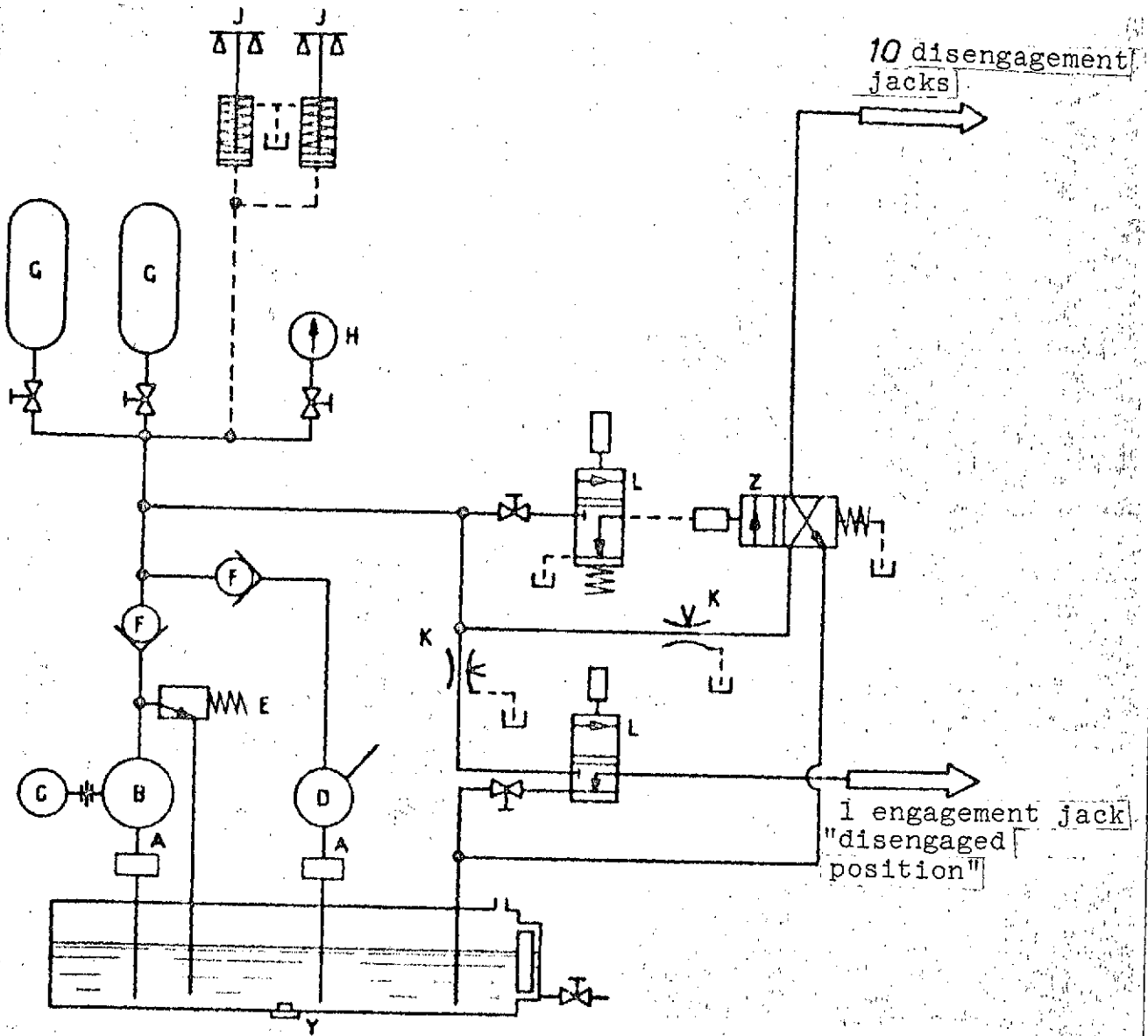

Figure 8. Hydraulic controls

Clutch

Figure 8 (Cont'd)



- A: Filter
- B: Pump
- C: Electrical motor
- D: Hand pump
- E: By-pass
- F: Anti-return Valve

- G: Accumulator
- H: Manometer
- J: Manometer contact
- K: Choke
- L: Electrical valve
- Y: Magnetic stopper
- V: Hydraulic valve



Figure 8 (Cont'd)

Brake

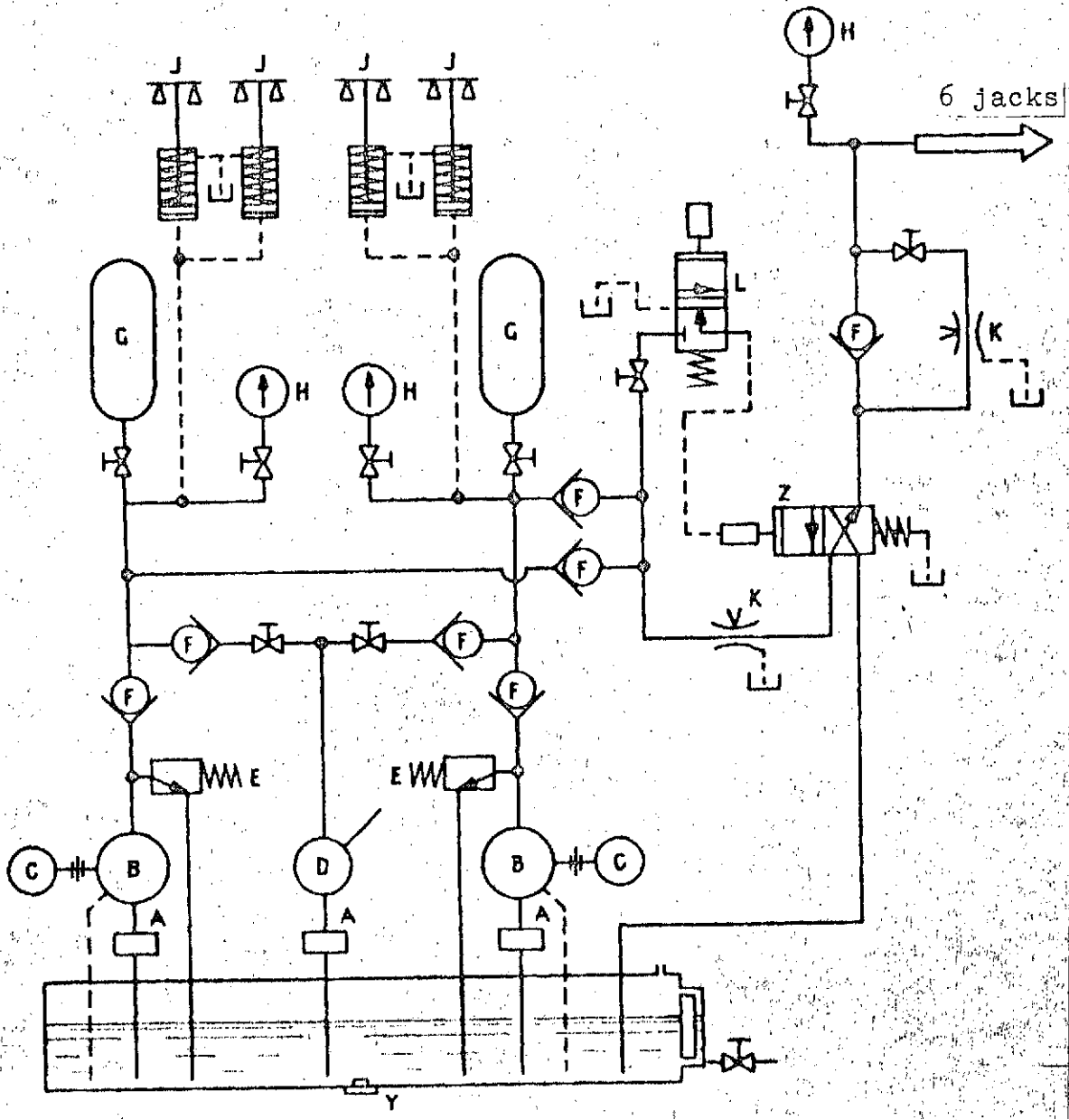

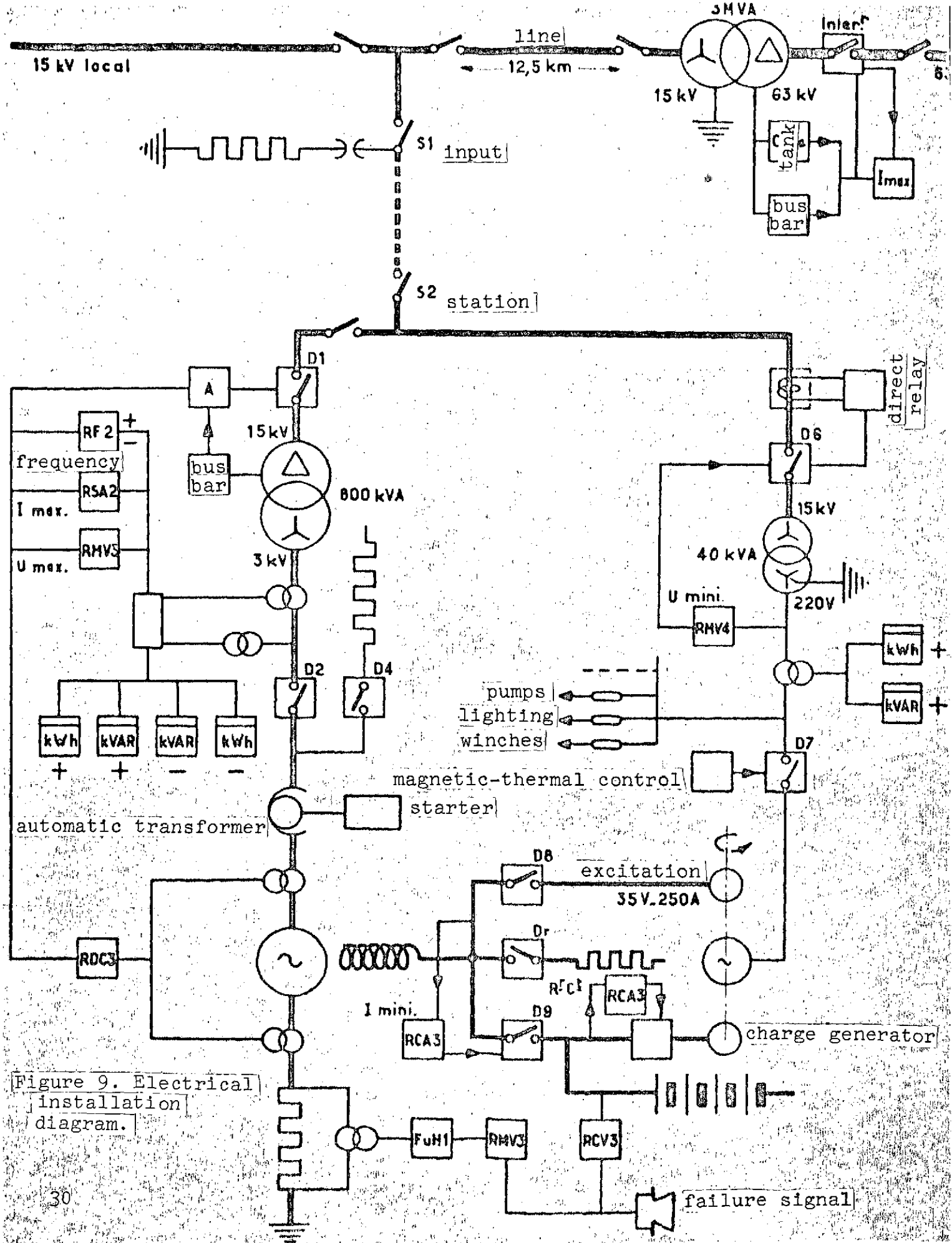

Figure 9. Electrical installation diagram.

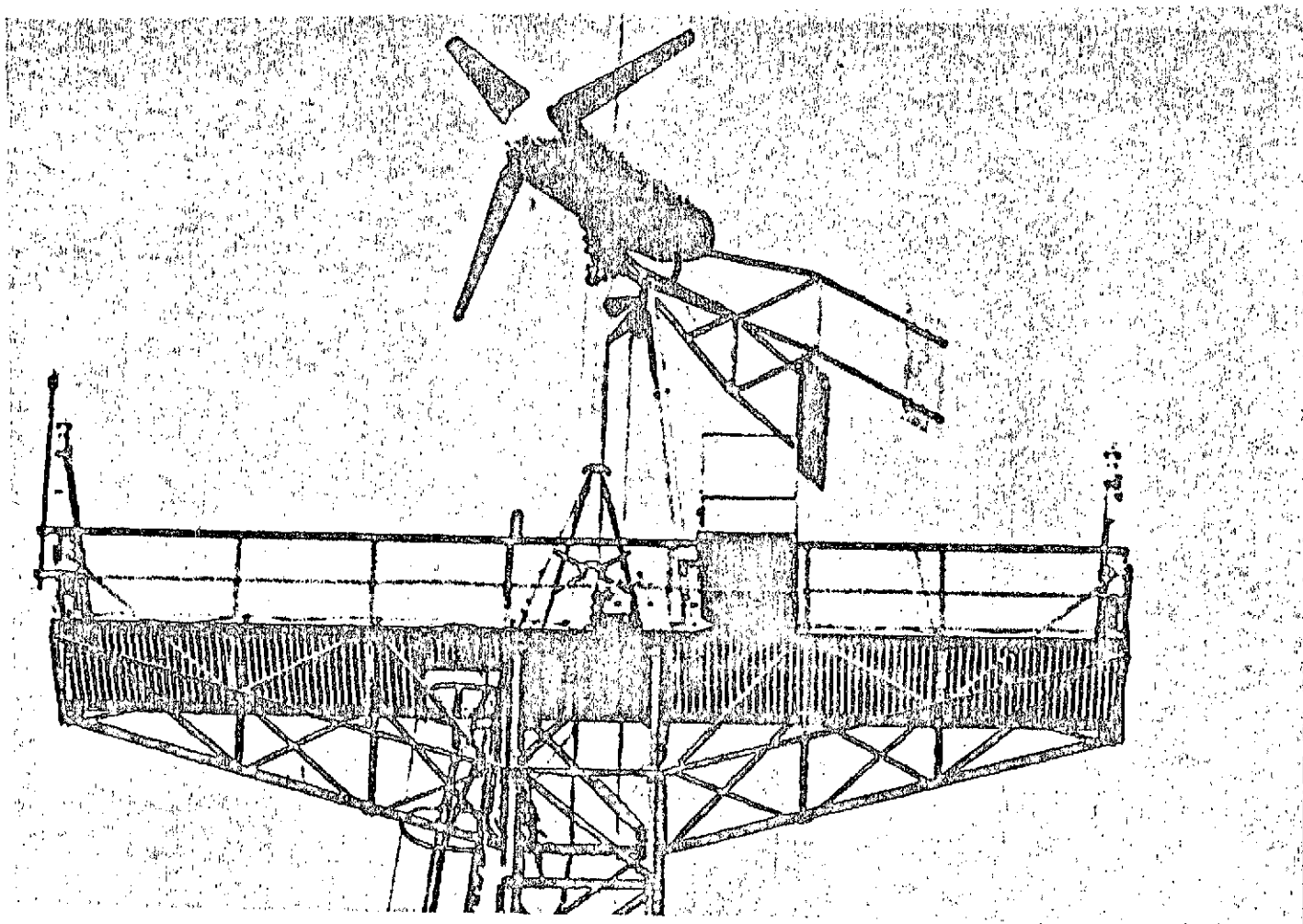

Figure 1.

Figures 1-2. Before constructing the 30.19 meters aerogenerator (diameter of the eolian propellor) numerous aerodynamic studies were carried out, including investigations at the Eiffel wind tunnel, the Chalais Meudon wind tunnel and the St. Cyr School wind tunnel. Investigations in natural wind were carried out at Poitiers.

Figures 1 and 2 show the 1/8 scale model and the 1/20 model of the aerogenerator.

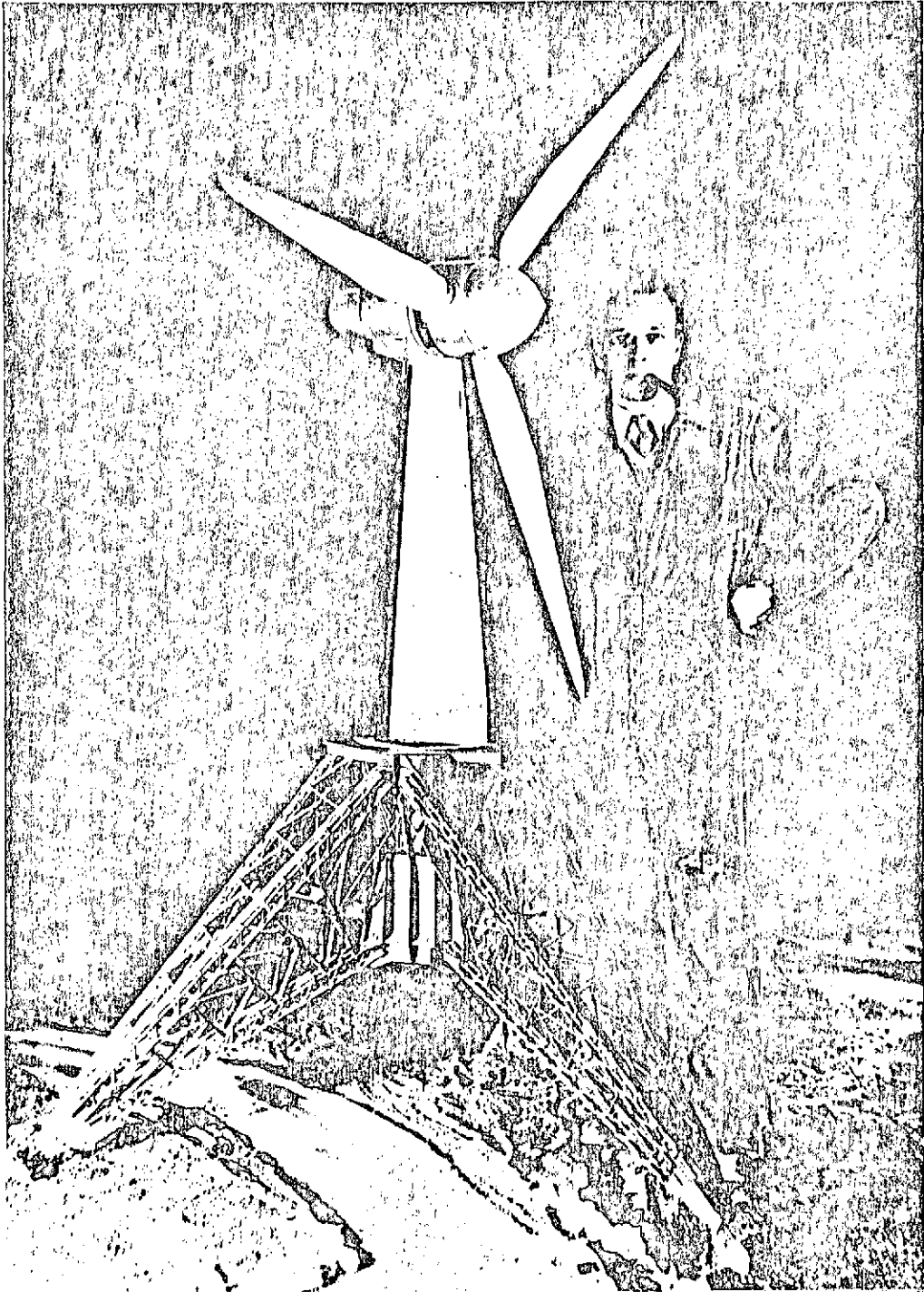

Figure 2.

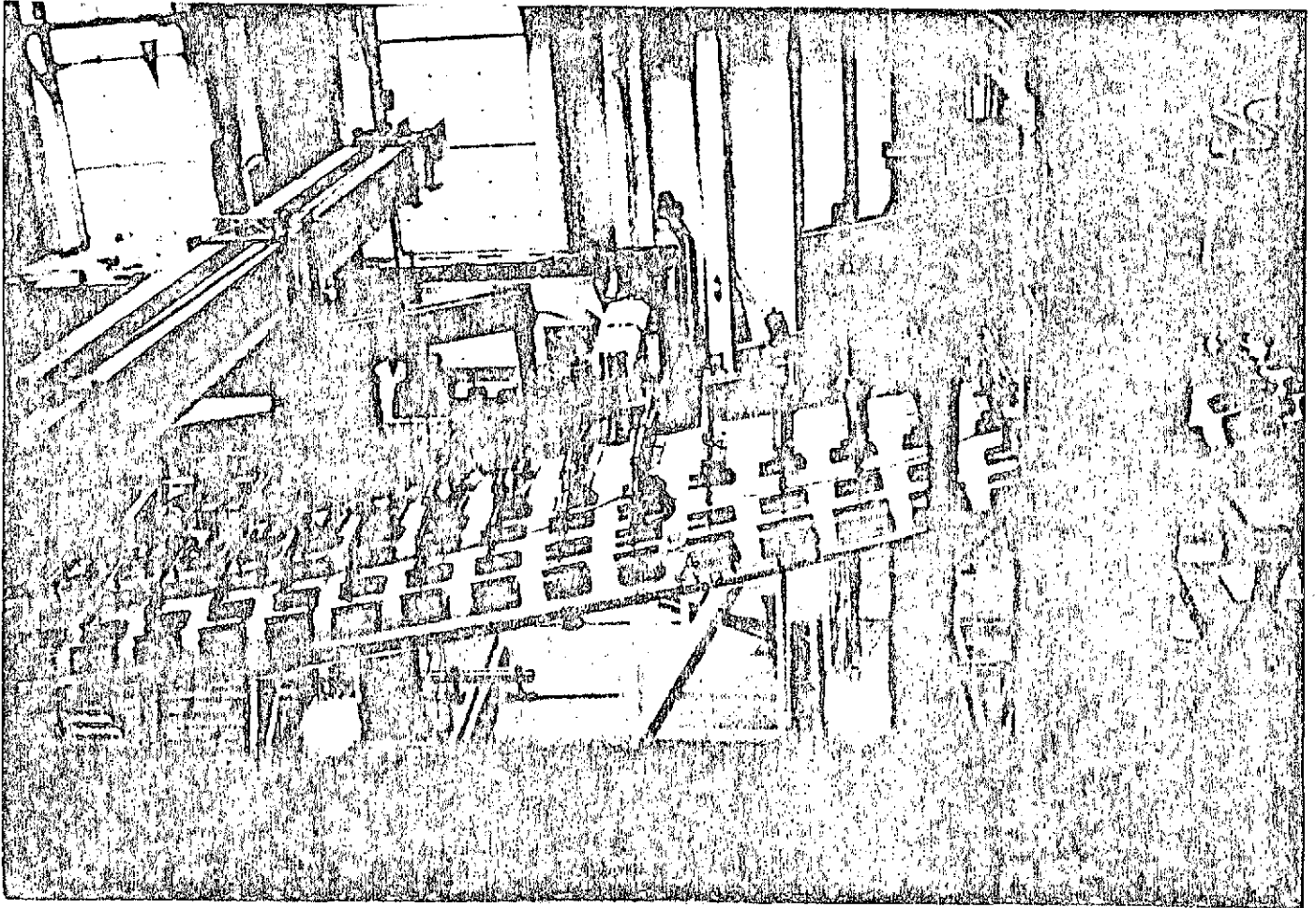

Figure 3. The same tests were done to determine the strength of the materials. (Deformation under a load, fatigue because of alternating loads, measurement of vibration periods, etc.) Various elements of the eolian propellor and elements of the transmission system were tested. This was done at the public works and building laboratories, at the bridge laboratory and at the facilities of the contractor. The figure shows a destruction test of a full-sized blade at the aeronautical facility at Toulouse.

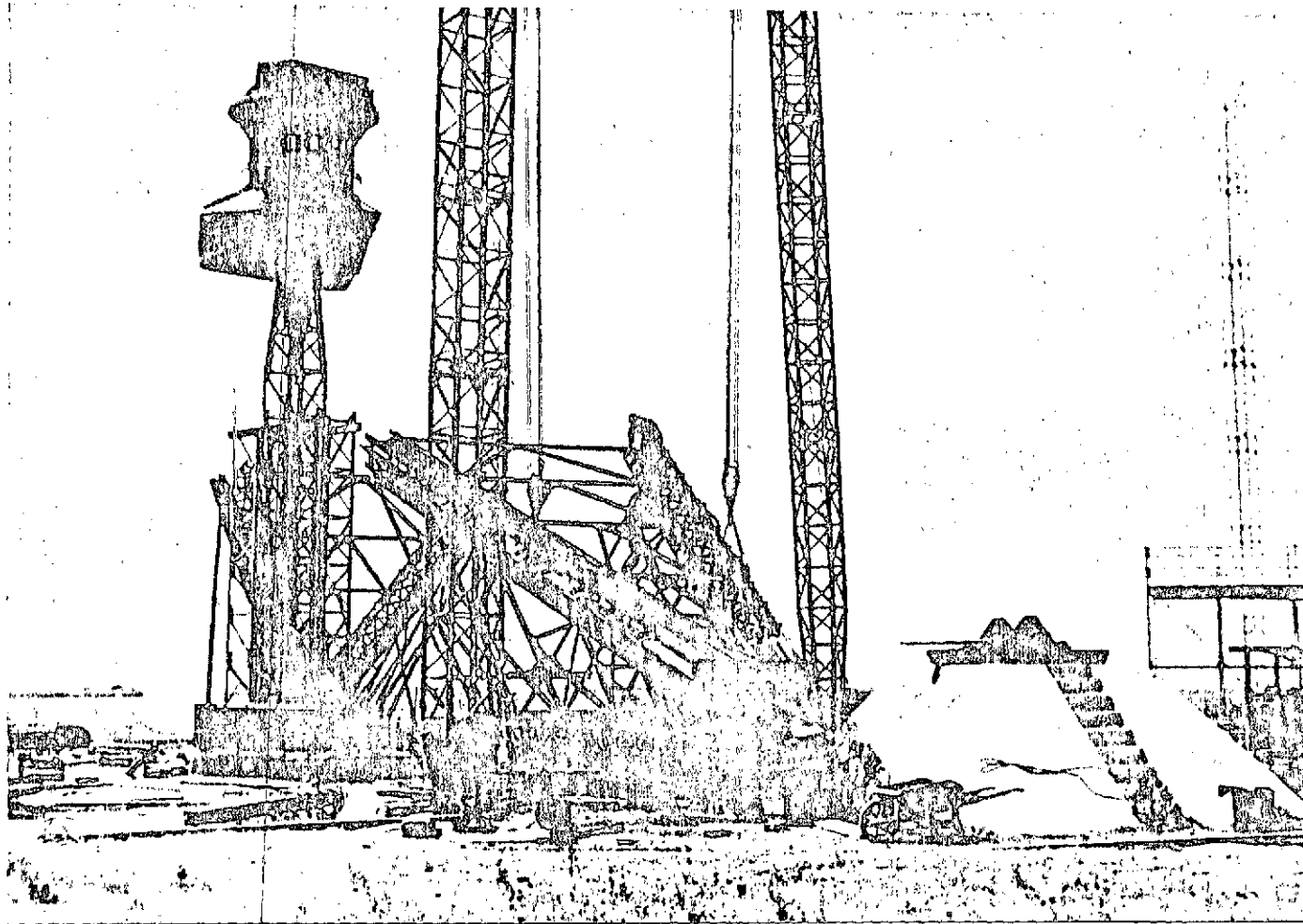

Figure 4. In the figure one can distinguish the concrete structure. It shows the support around which the tilting pylon foot will turn. The pylon rests on the ground. Suspended in mid-air, we can observe the socket which will support the lower part of the moveable pivot.

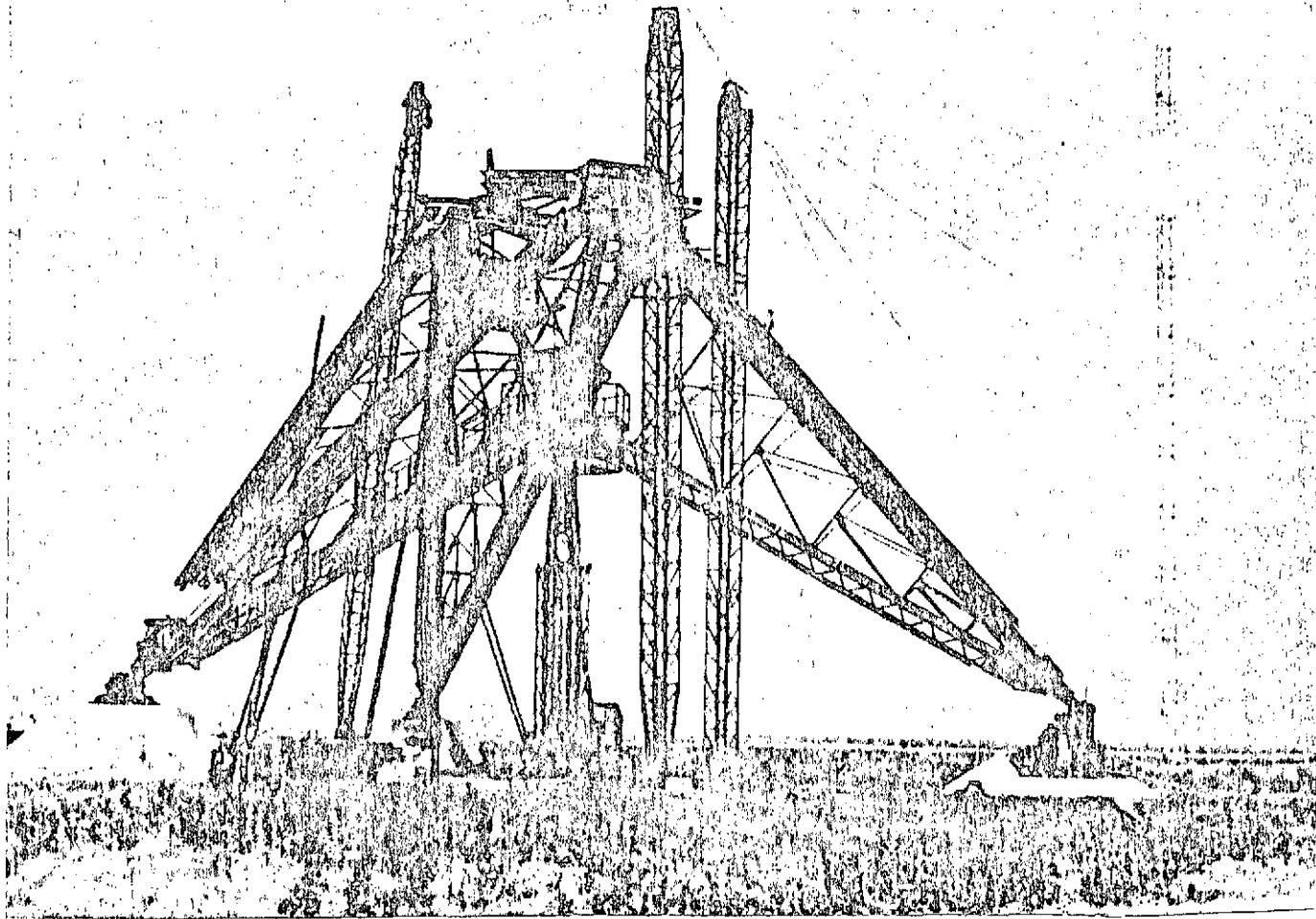

Figure 5. View of the pylon during construction.

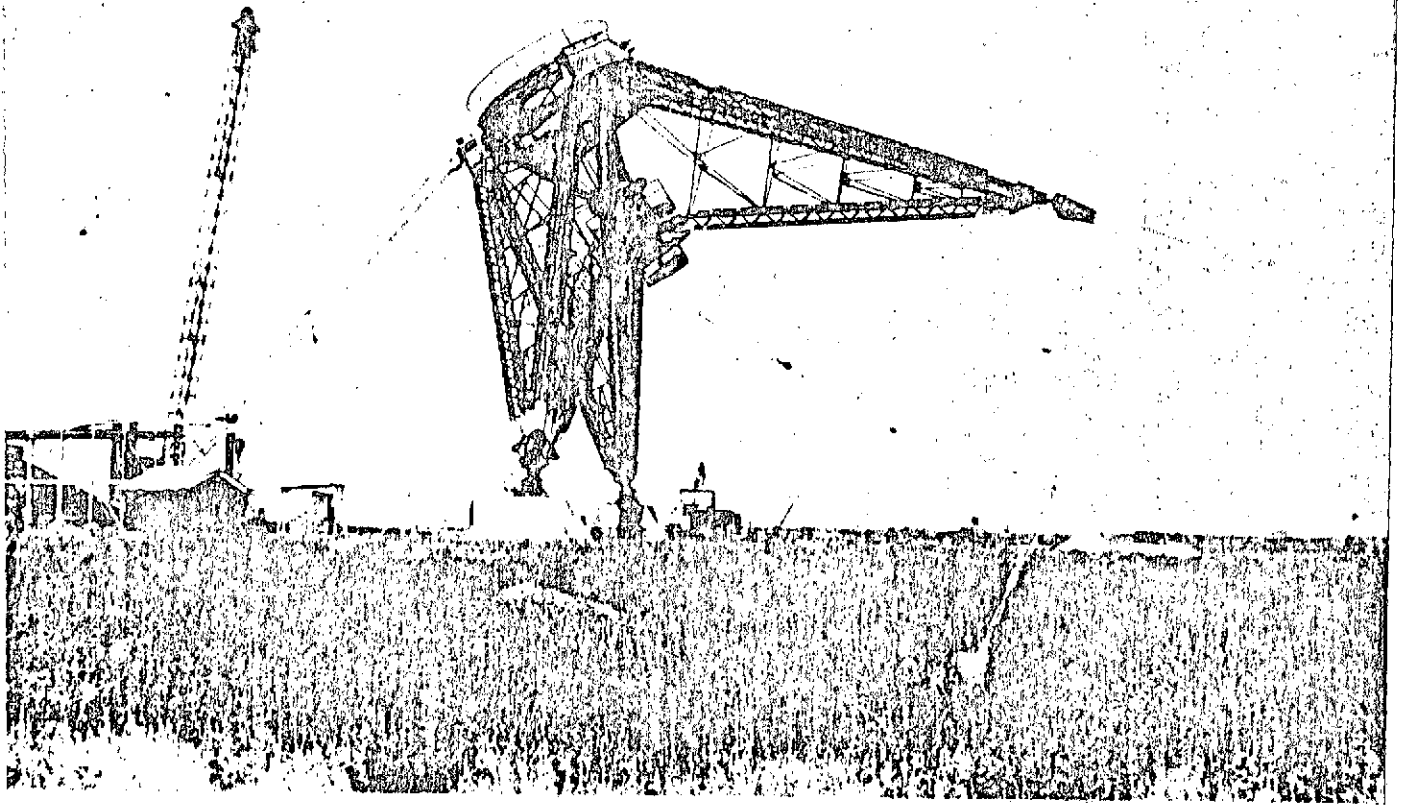

Figure 6. The pylon is shown during the tilting operation and is being tilted around two of its legs. The cables which connect it with the North arm are still under tension. After the structure has reached equilibrium, the connection with the moveable South foot will be set into operation in order to reduce the descent velocity.



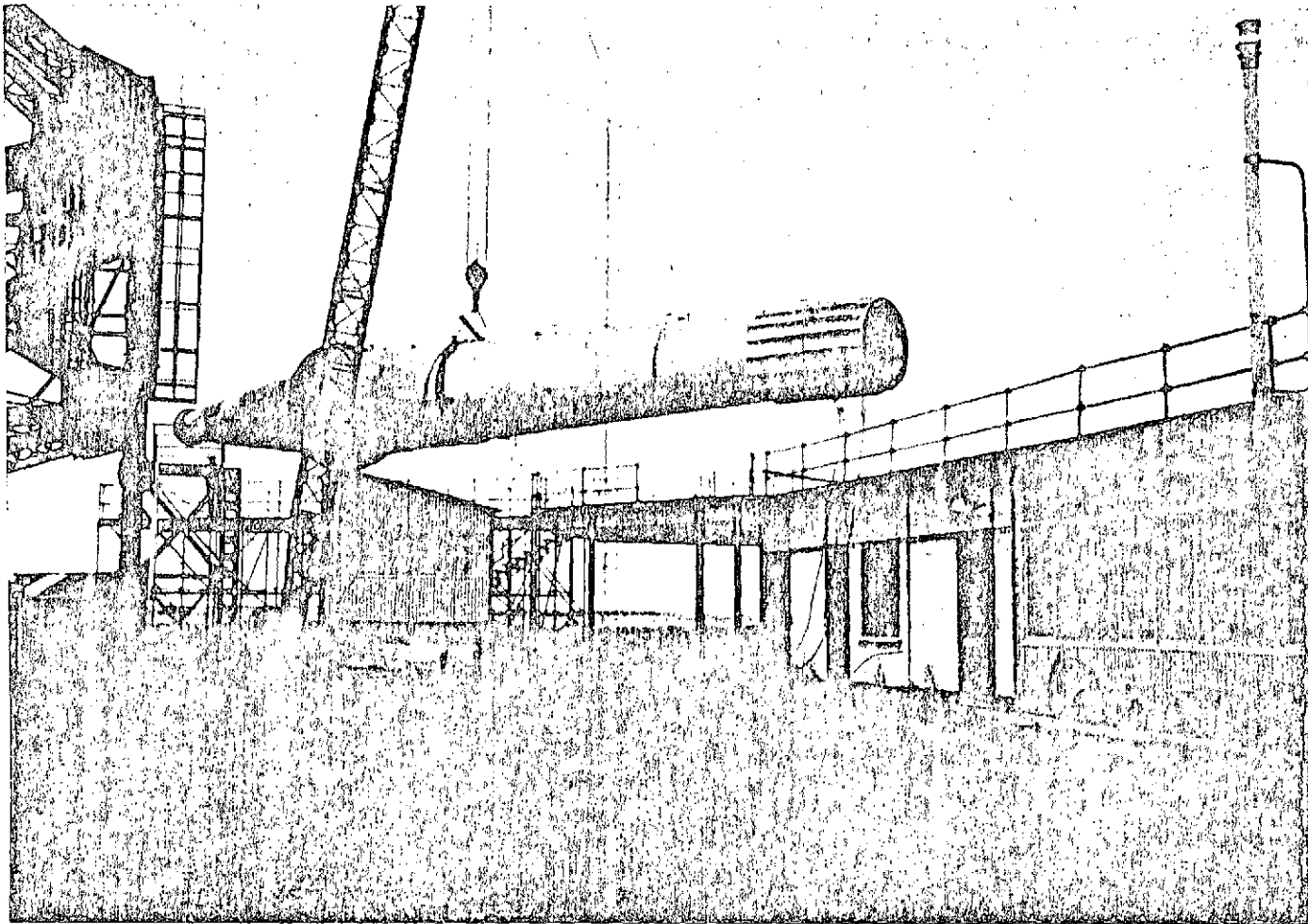

Figure 7. This photograph of the left side shows the upper part of the tilting pylon which rests on a portico and which will contain the pivot. On the right side, we can observe the windows of the electrical and transformation station. Through the windows we can observe the control and measurement room.

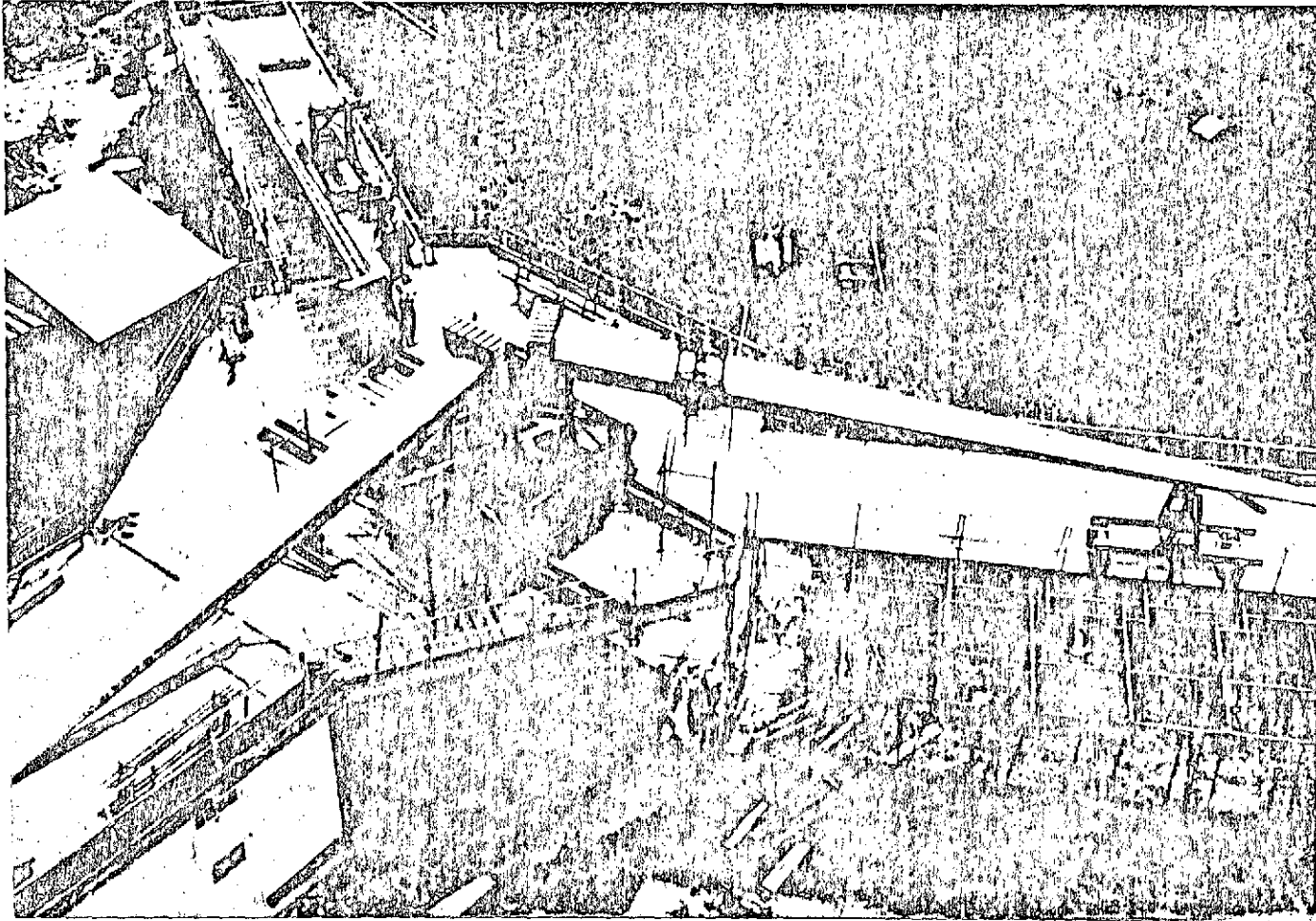

Figure 8.

Figures 8-9. The blade caisson is made of unoxidizable alloy. It is shown during assembly onto the steel hub. The lower member rests on a construction supported by the mounting platform. Electrical cables are shown which measure the stresses in the blades.

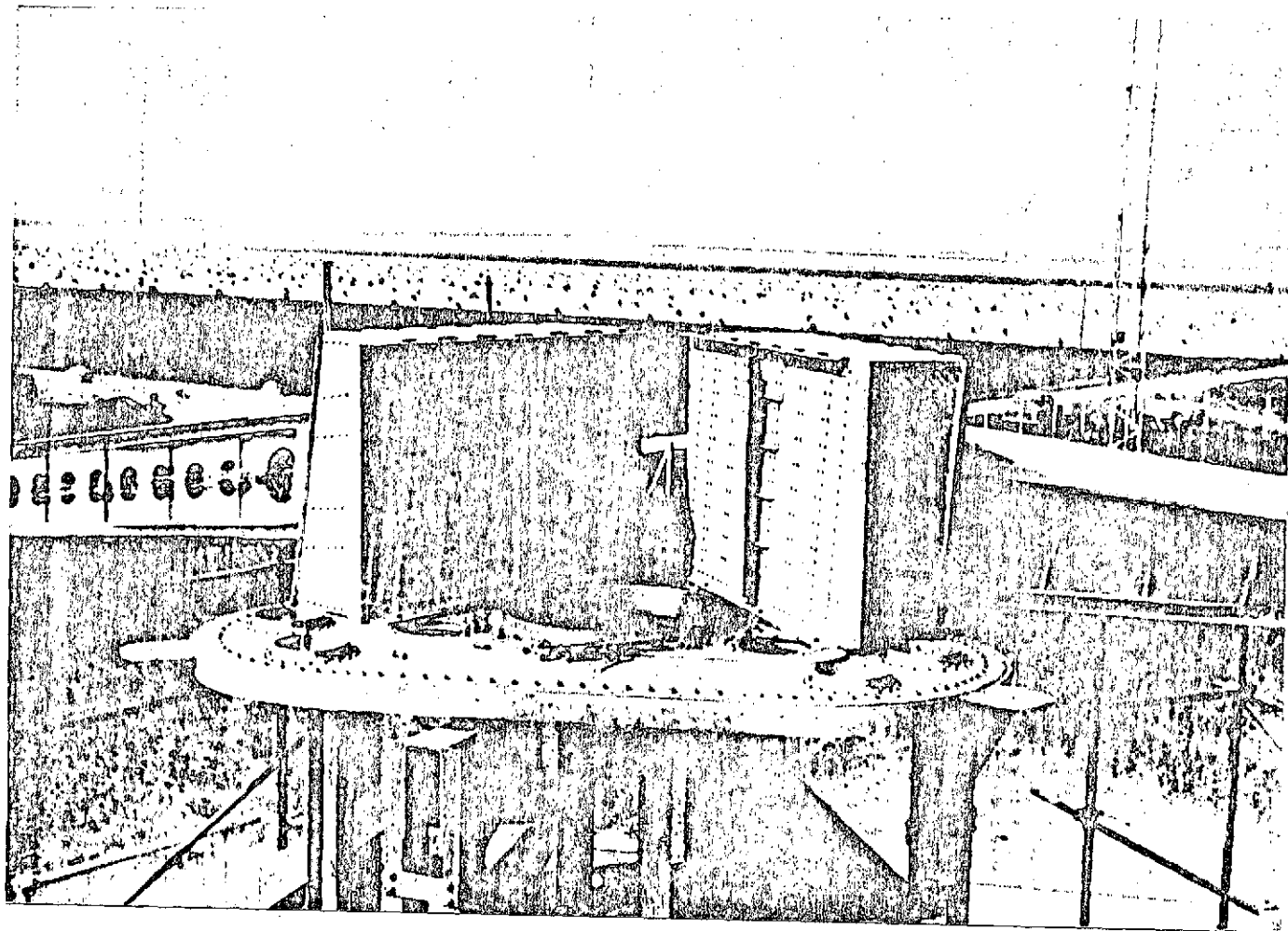

Figure 9.

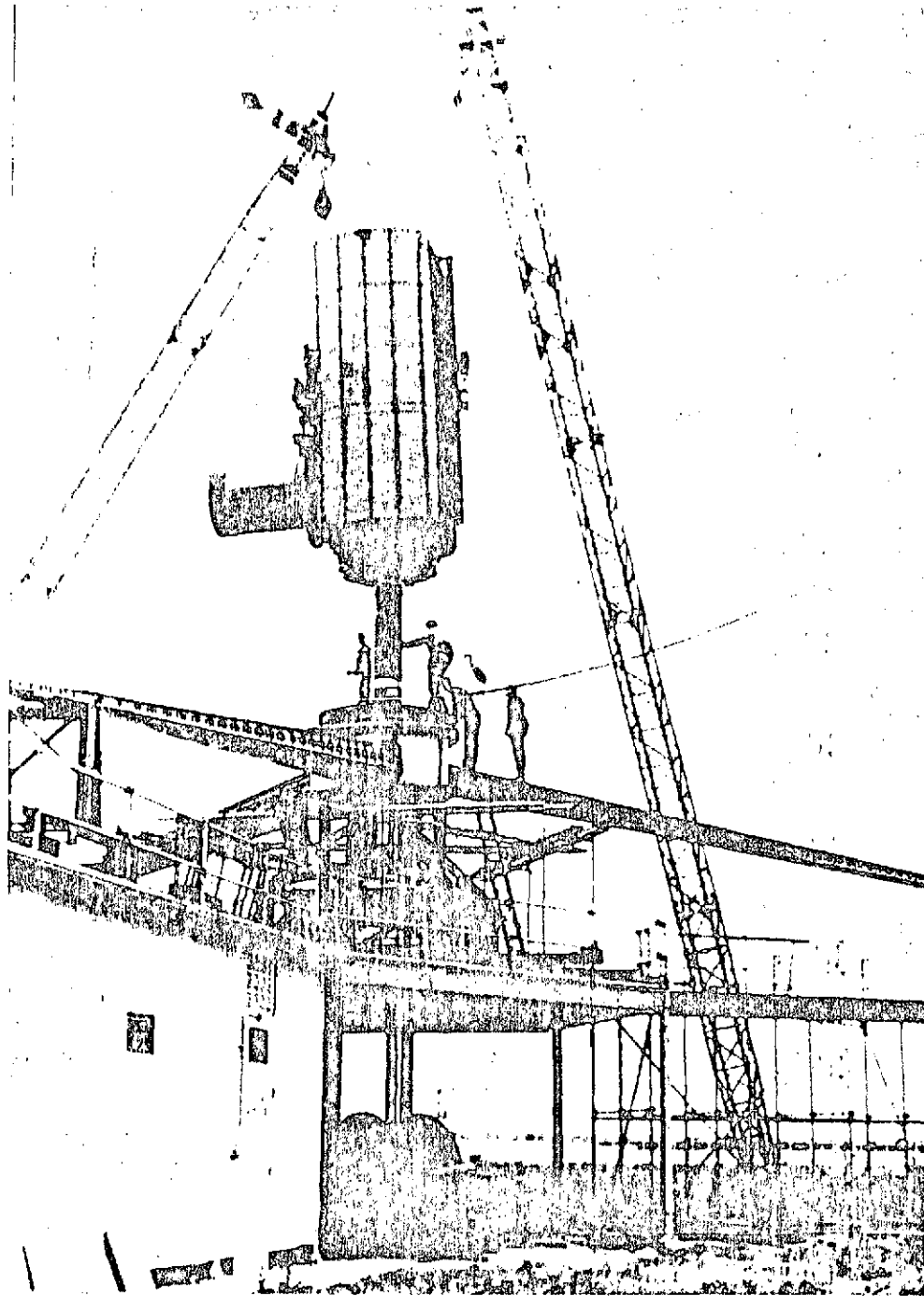

Figure 10. Above the hub of the eolian propeller, we observe the following from bottom to top; the lantern wheel which is activated by a gear pinion which makes it possible to rotate the propeller by hand, the journal, then the brake and then the nacelle.

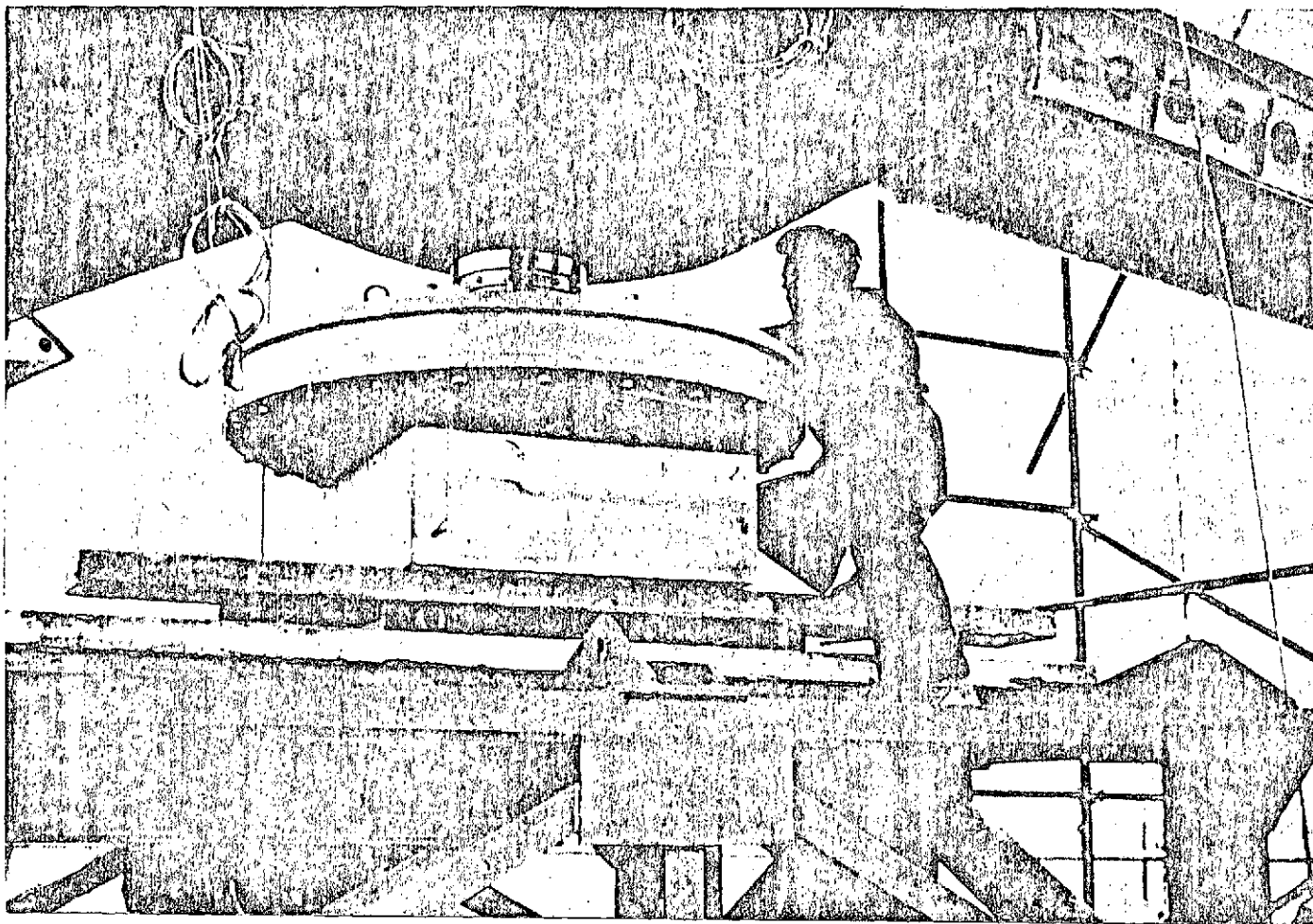

Figure 11. The first gear wheel is placed above the propellor hub, which had been raised beforehand.

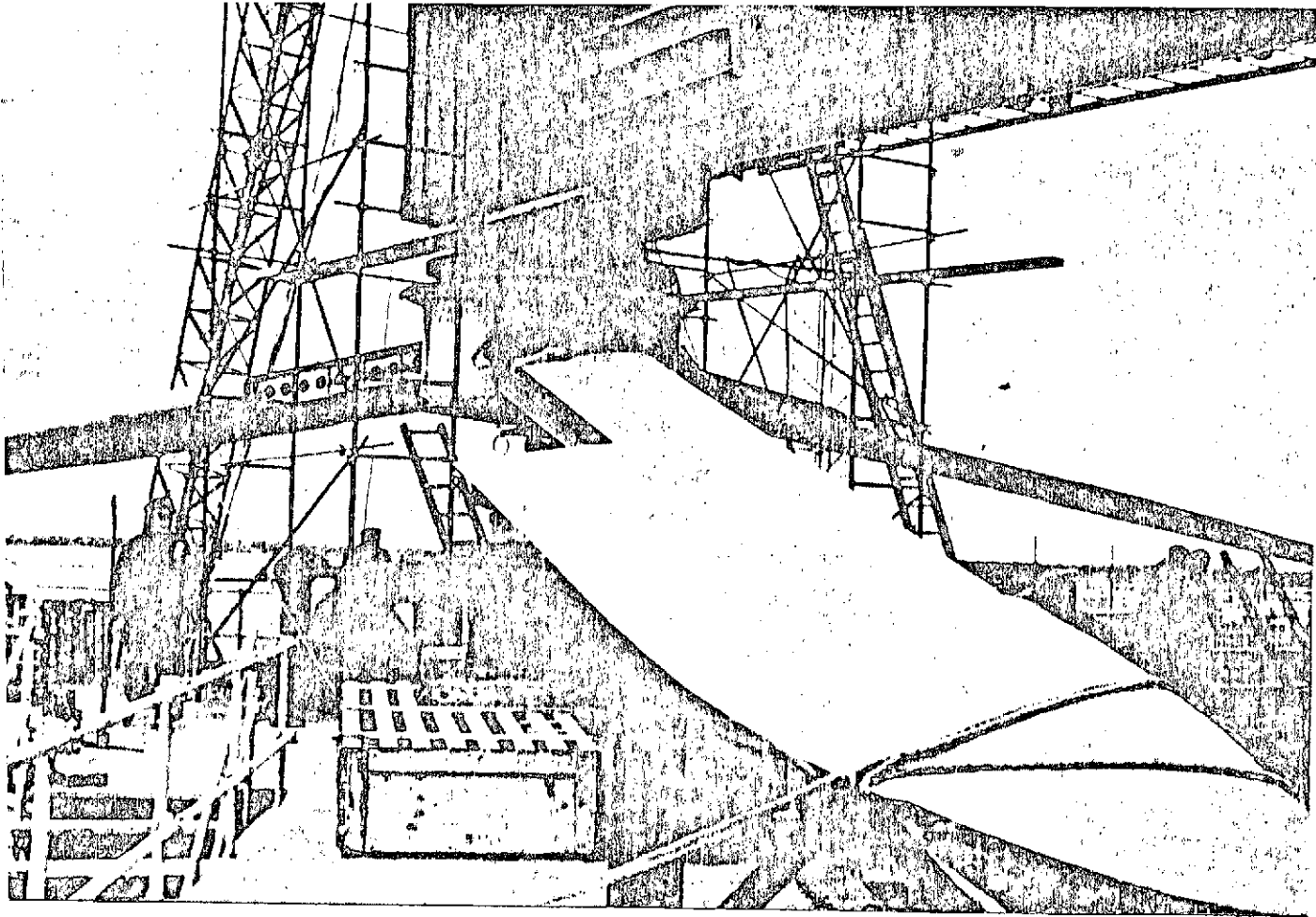

Figure 12. At the same time the trailing edges of the blade and the leading edges containing "spoilers" are installed.

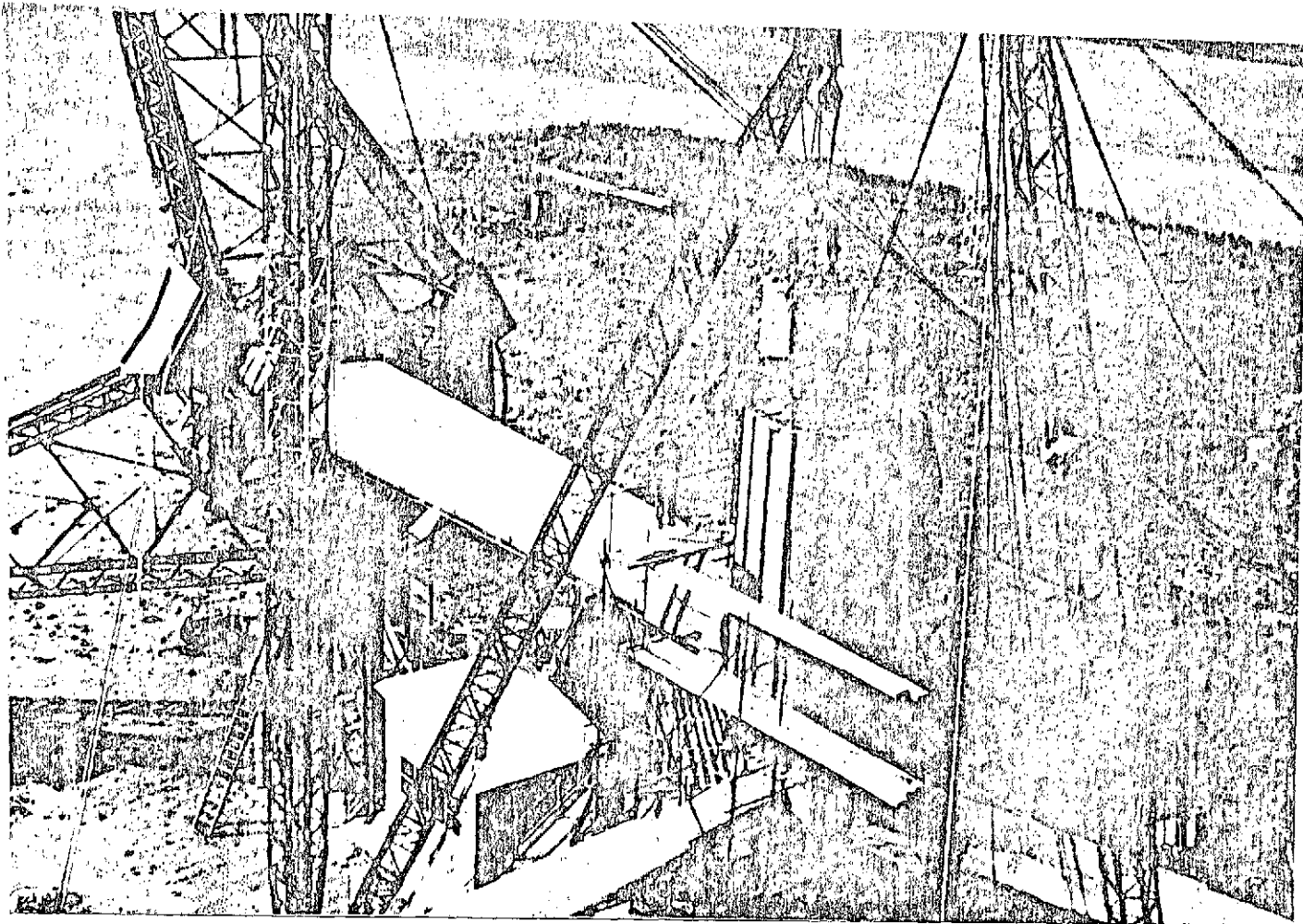

Figure 13. Once the nacelle is covered within the pivot, the 640 kW generator is brought into final position. The second gear train is already installed in the upper support.

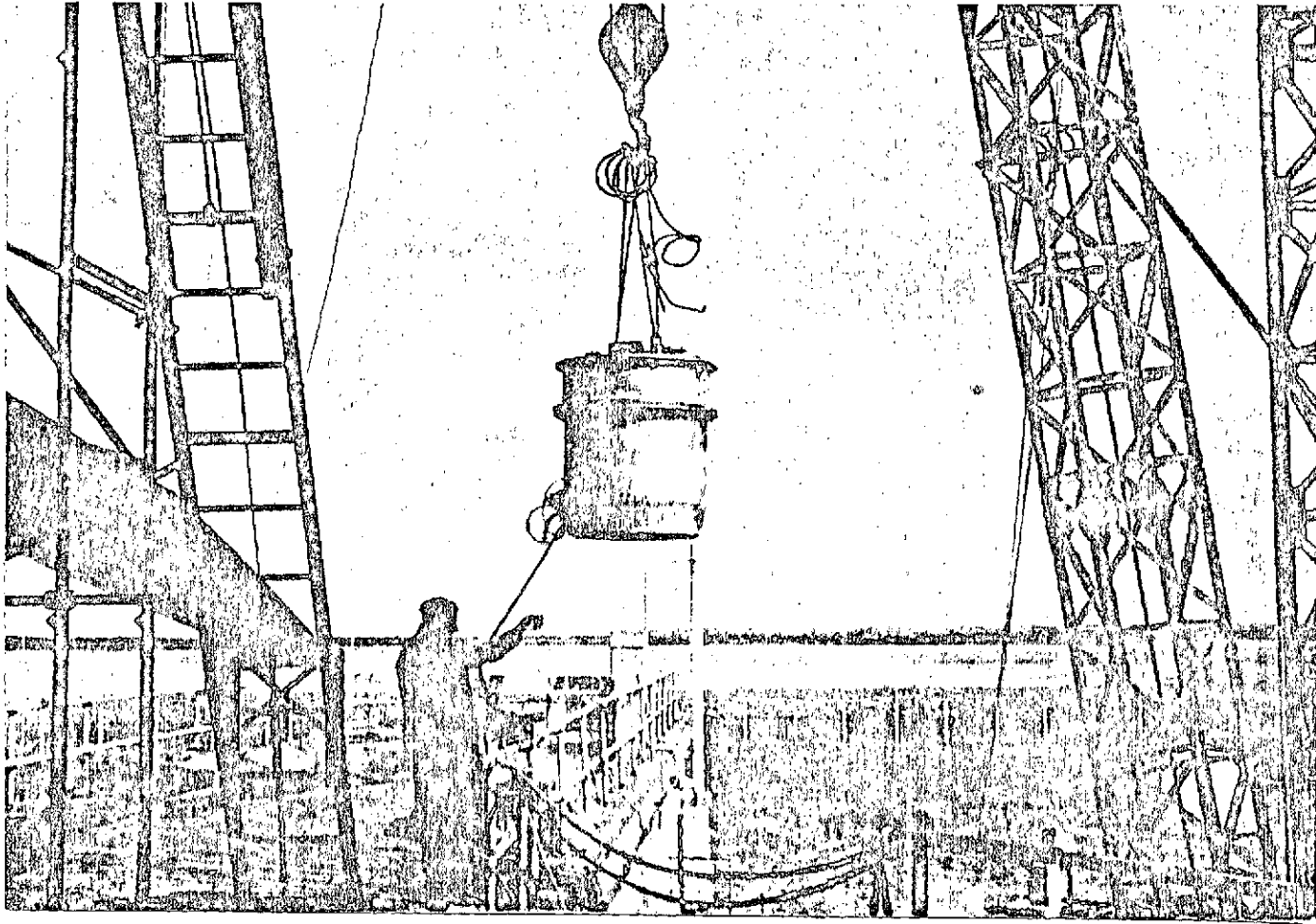

Figure 14. The clutch is lifted onto its tower.



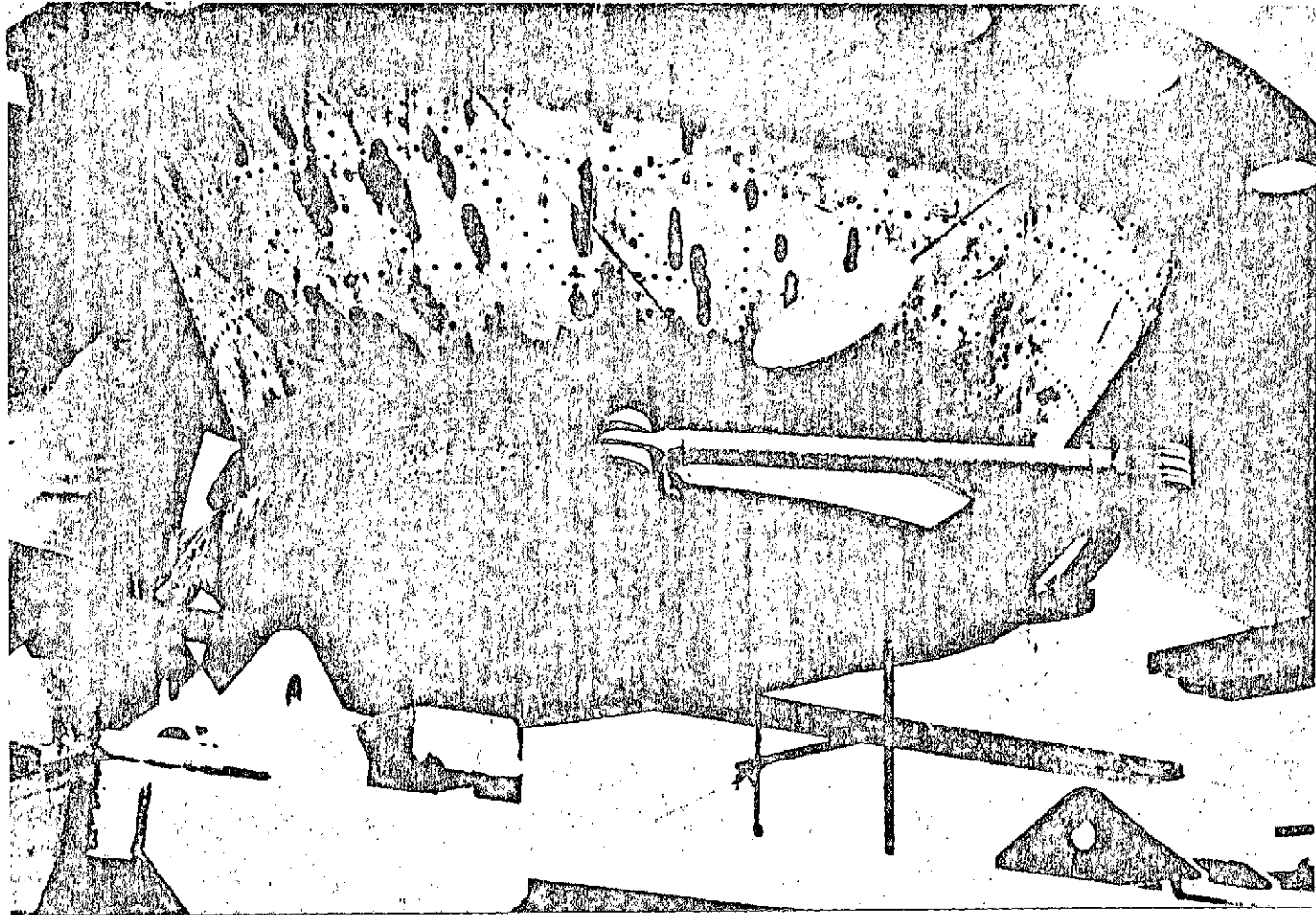

Figure 15. A coupling of the model utilized for electrical locomotives connects the propeller hub to the first gear train. Only couples can be transmitted.

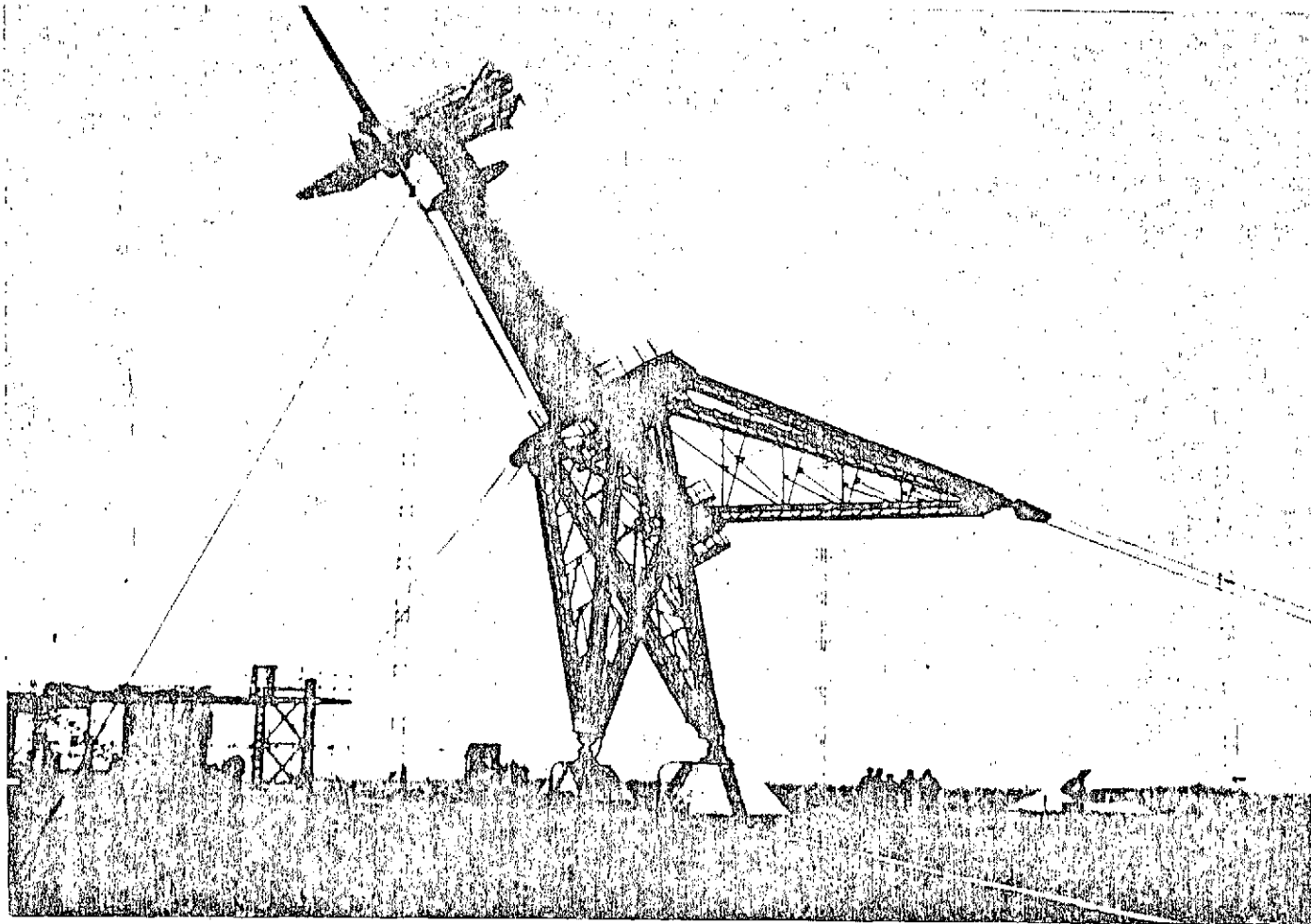

Figure 16. The aerogenerator is in the process of being raised. The operation lasts 55 minutes in all.

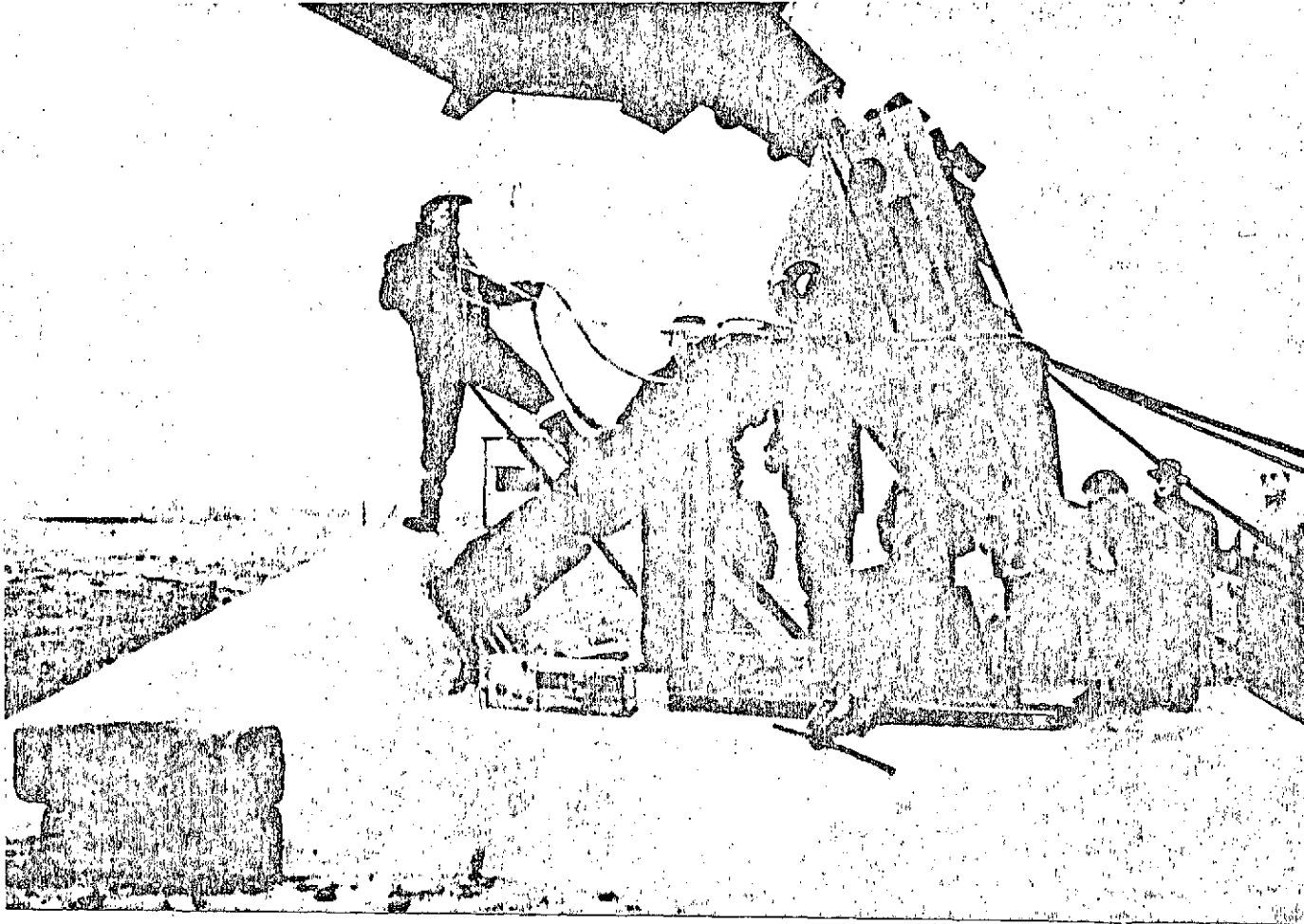

Figure 17. The moveable foot is being attached to the concrete substructure.

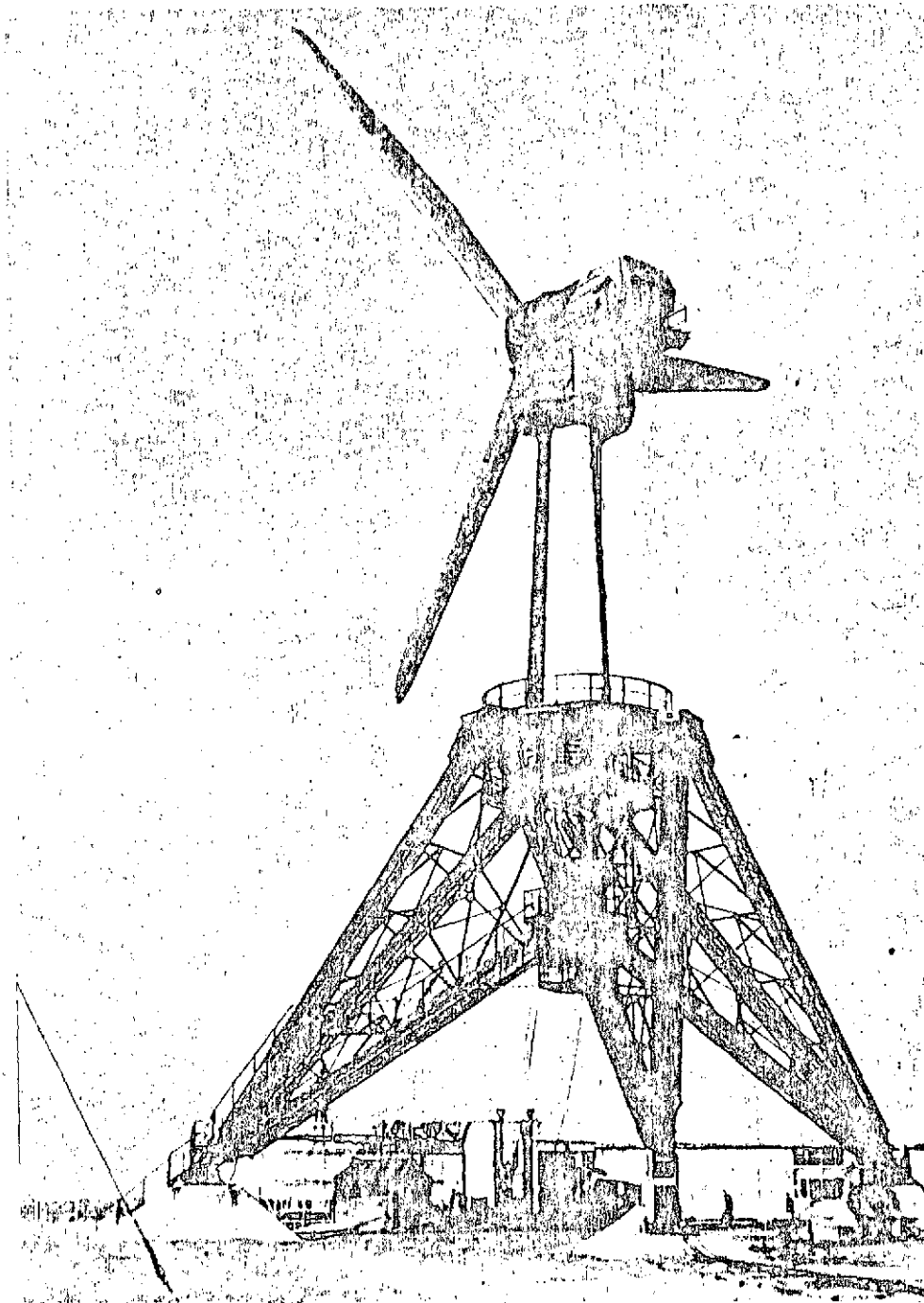

Figure 18. The aerogenerator has been erected. The final fairings must be installed and the nacelle is surrounded by protective covering members.

Translated for National Aeronautics and Space Administration under contract No. NASw 2483, by SCITRAN, P. O. Box 5456, Santa Barbara, California, 93108.